



END SUCTION CENTRIFUGAL PUMPS

NM SERIES
(50 Hz)

NM End Suction Centrifugal Pumps

General Information

Fields of Application

- Water supply and booster stations.
- Irrigation, overhead irrigation and draining.
- Filling and emptying of tanks and containers.
- Circulating of hot and cold water in central heating and air-conditioning installations.
- Pumping of condensate.
- Water circulating for swimming pools.
- Sanitary and cleaning installations.
- For industrial applications and public services.
- Fresh water supply on ships.

Pumped Liquids

Thin, clean, non-aggressive and non-explosive liquids free from large solid particles or fibres.

Design

- Single-stage, end suction, centrifugal volute pump.
- Main dimensions according to EN 733 (DIN 24255).
- In addition to 25 basic sizes conforming to norms, we have developed 21 additional sizes. So we have 46 sizes of pumps.
- Single entry, closed impeller is hydraulically thrust compensated and dynamically balanced.
- Pump and motor are separate components, connected to each other via a flexible coupling and mounted on a common base plate.
- Maintenance is very much easier, the impeller shaft and other rotating parts being removable with no need to disconnect the suction and delivery pipes.
- In fact the use of one extension coupling enables a pump to be dismantled without moving either the driver or the pump casing.
- Maximum interchangeability of components, identical parts can be used with various sizes of a pump, which greatly simplifies and reduces stock of spare parts.

Bearings

The pump has sturdy maintenance-free antifriction bearings, which are greased for life with high-temperature grease. A deflector on the shaft prevents leakage fluid from getting into bracket.

Shaft Seal

Pumps are supplied as standard a conventional packet gland, lantern ring for water sealing and lubricating of packing.

- Uncooled stuffing box without shaft sleeve is standard. (Up to 90 °C)
- Uncooled mechanical seal with or without shaft sleeve is optional. (Up To 90 °C)
- Water cooled stuffing box or mechanical seal is optional. (90 – 140 °C)

Technical Data

- Suction Nozzle..... : DN 50 ...DN 400
- Discharge Nozzle..... : DN 32....DN 350
- Operating Pressure..... : 10 Bar
- Casing Test Pressure.... : 13 Bar
- Impeller Diameter mm ø : 160...500 mm ø
- Speed Range..... : 1000 – 3600 RPM
- Capacity Range..... : 5 – 3000 m³ / h
- Head Range..... : 4 - 105 m

Pump Flanges

- Discharge Flanges: DIN 2533 – PN 16
- Suction Flanges : 32-200 DIN 2533 PN 16
250 , 400 DIN 2533 PN 10

Identification Code

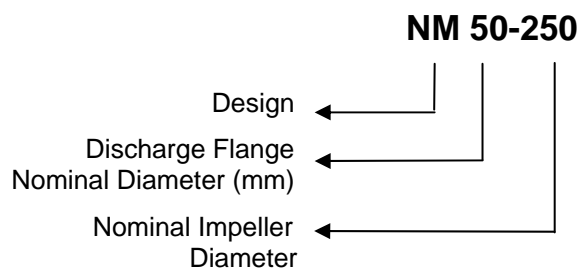

NM End Suction Centrifugal Pumps

Interchangeability for Pumps

A	1	A 1	32-160								- 6305	
	2		40-160									
	3		50-160									
	4		65-160									
	5		80-160									
	6	A 2	100-160								- 6305	
	7		32-200									
	8		40-200									
	9		50-200									
	10	65-200	A 3	32-250								- 6305
	11	40-250										
	12	50-250										
	13	50-250										
B	14	B 1	80-200								- 6308	
	15		100-200									
	16		125-200									
	17		150-200									
	18	B 2	65-250								- 6308	
	19		80-250									
	20		100-250									
	21		125-250									
	22	150-250	B 3	50-315								- 6308
	23	65-315										
24	80-315											
25	100-315											
26	100-315	B 4	65-400								- 6308	
C	28	C 1	200-280								- 6310	
	29	C 2	125-315								- 6310	
	30		150-315									
	31		200-315									
	32	C 3	80-400								- 6310	
	33		100-400									
	34		125-400									
35	150-400											
D	36	D 1	250-315								- 6312	
	37	D 2	200-400								- 6312	
	38	D 3	150-500								- 6312	
	39	D 4	300-315								- 6312	
E	40	E 1	250-400								- 6312	
	41		300-400									
	42	E 2	200-500								- 6312	
	43		250-500									
	44		E 3									350-450

Casing Impeller Stuffing Box Shaft Bearing

Bearing Housing Suction Cover Bearing Cover



WATER PUMPS

NM End Suction Centrifugal Pumps

Performance Range

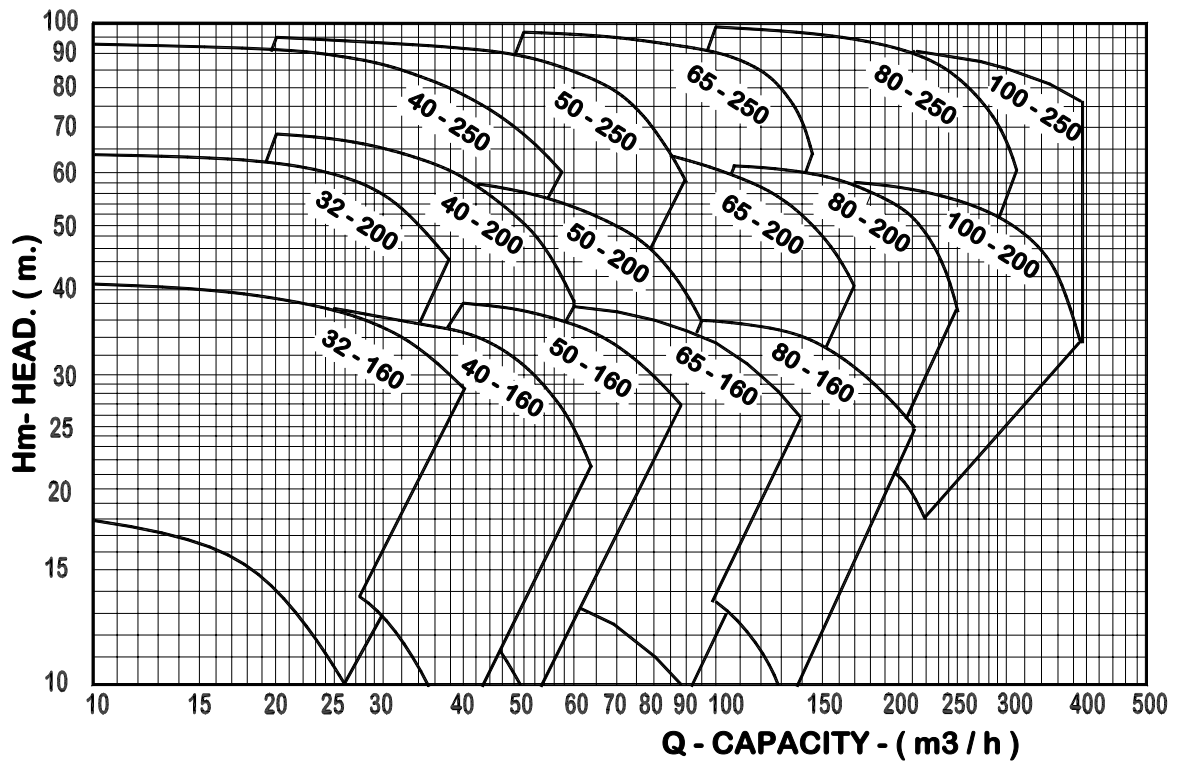
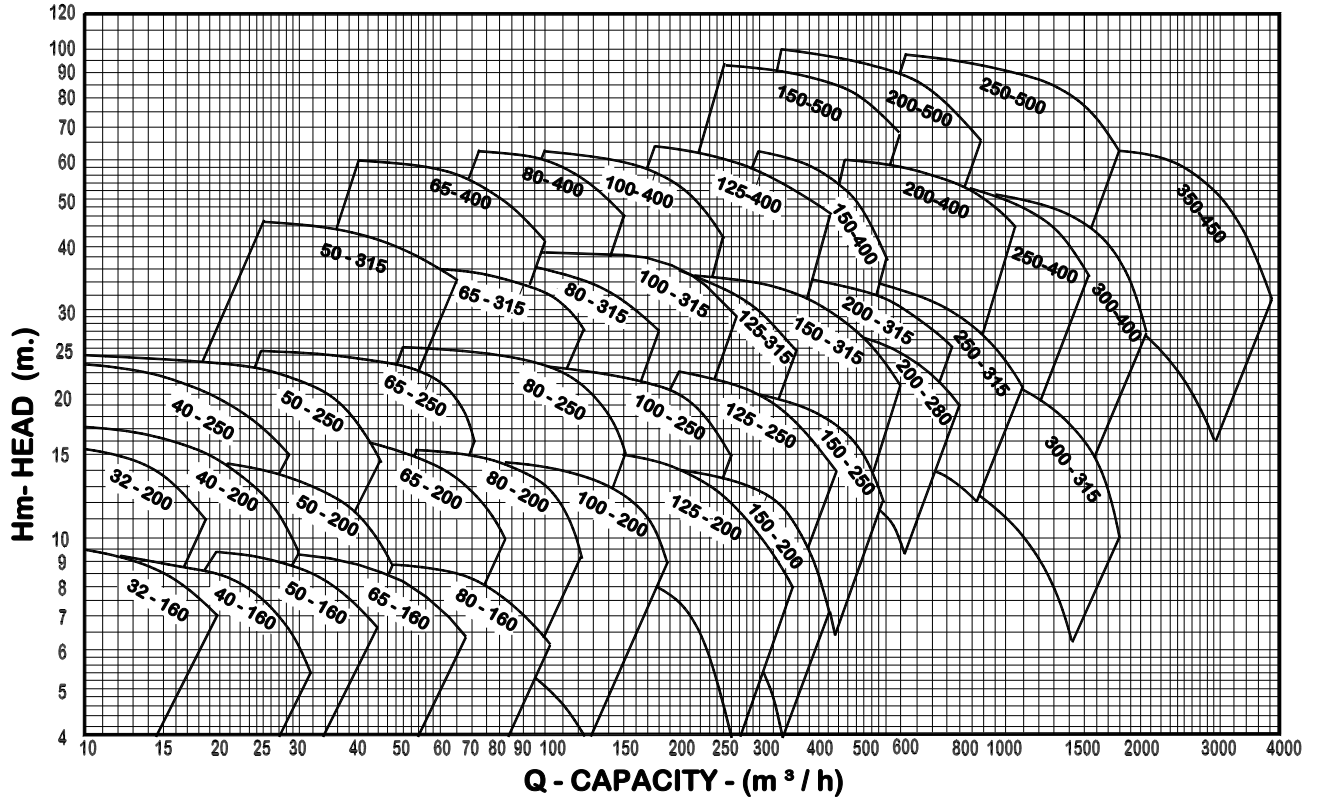

NM End Suction Centrifugal Pumps

Cross-Sectional View of End Suction Centrifugal Pump

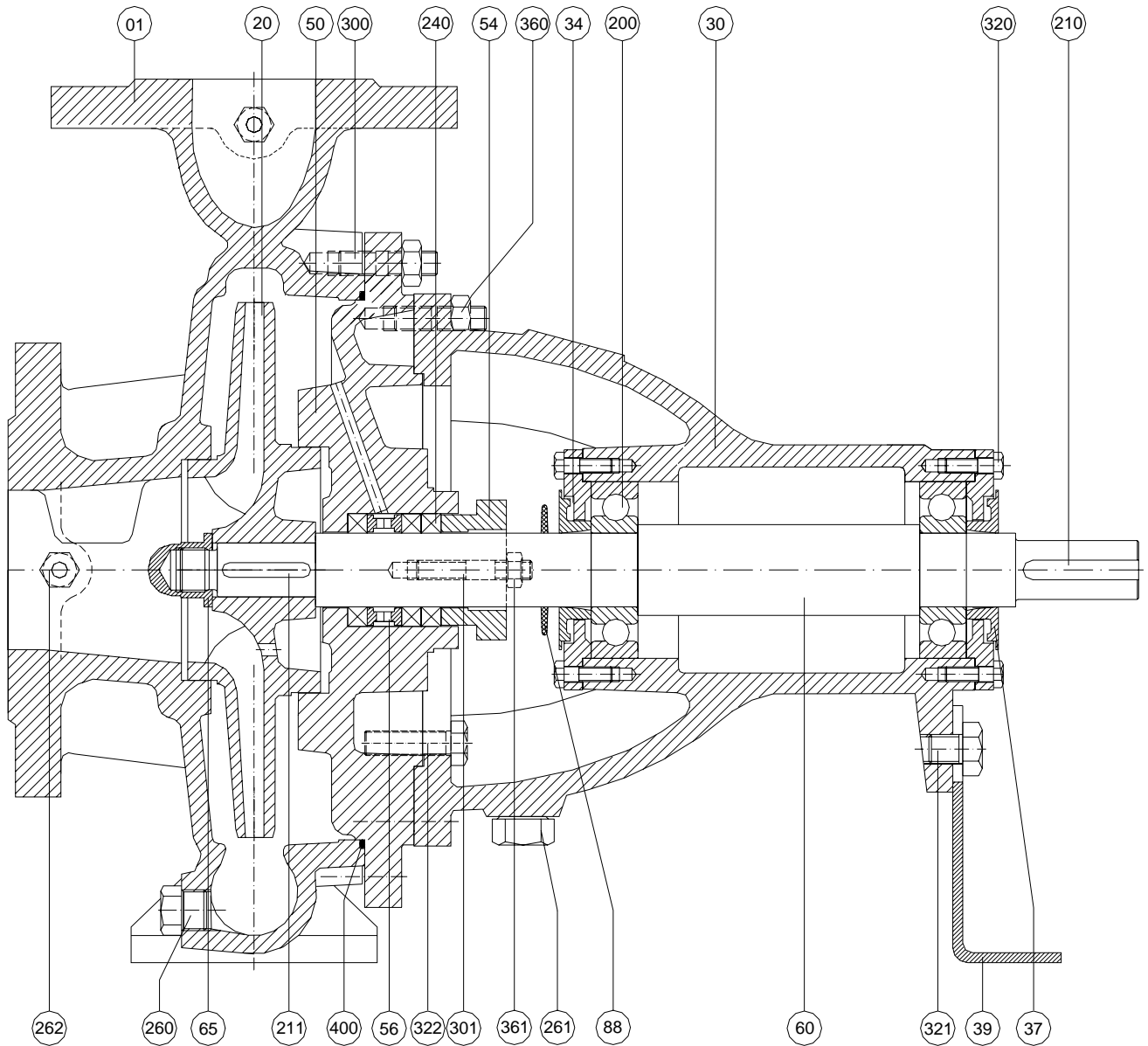

PART NO	PART NAME	PART NO	PART NAME
01	Pump Casing	211	Impeller Key
20	Impeller	240	Gland Packing
30	Bearing Housing	260	Drain Plug
34	Bearing Housing Cover	261	Plug
37	Lip Seal	262	Plug
39	Supporting Part	300	Stud
50	Stuffing Box	301	Stud for Gland
54	Gland	320	Hexagonal Bolt
56	Lantern Ring	321	Hexagonal Bolt
60	Pump Shaft	322	Hexagonal Bolt
65	Impeller Nut	360	Hexagonal Nut
88	Water Thrower	361	Hexagonal Nut for Gland
200	Ball Bearing	400	O-Ring
210	Coupling Key		

NM End Suction Centrifugal Pumps

Cross-Sectional View of End Suction Centrifugal Pump

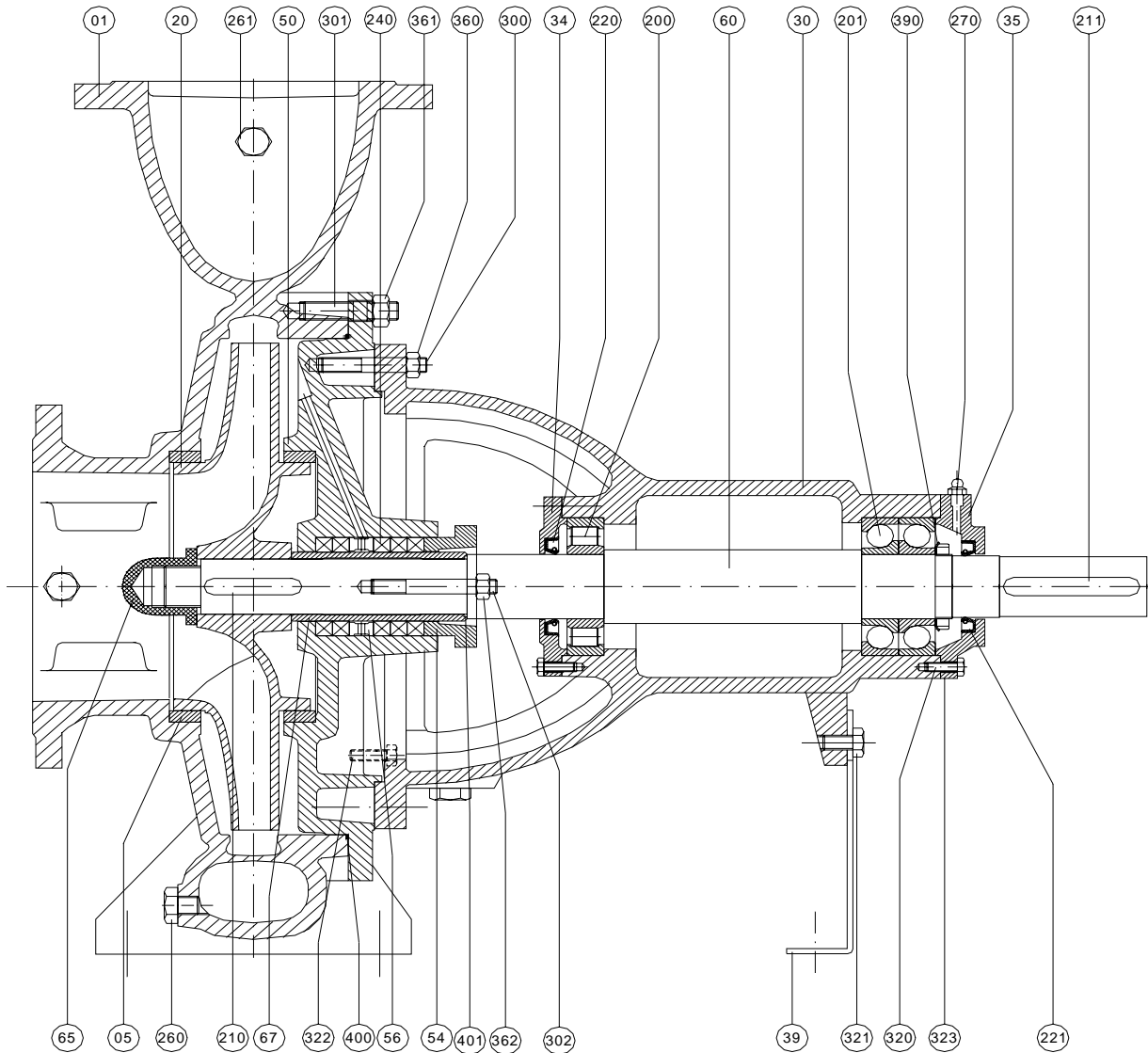

PART NO	PART NAME	PART NO	PART NAME
01	Pump Casing	221	Oil Seal
05	Wearing Ring	240	Gland Packing
20	Impeller	260	Drain Plug
30	Bearing Housing	261	Plug
34	Bearing Housing Cover	270	Greaser
35	Bearing Cover (Outside)	300	Stud
39	Supporting Foot	301	Stud
50	Stuffing Box	301	Stud for Gland
54	Gland	320	Hexagonal Bolt
56	Lantern Ring	321	Hexagonal Bolt
60	Pump Shaft	322	Hexagonal Bolt
65	Impeller Nut	323	Hexagonal Bolt
67	Sealing Sleeve	360	Hexagonal Nut
200	Bearing	361	Hexagonal Nut
201	Bearing	362	Nut for Gland
210	Impeller Key	390	Safety Ring
211	Coupling Key	400	O-Ring
220	Oil Seal	401	O-Ring

NM End Suction Centrifugal Pumps

Cross-Sectional View of End Suction Centrifugal Pump (With Mechanical Seal)

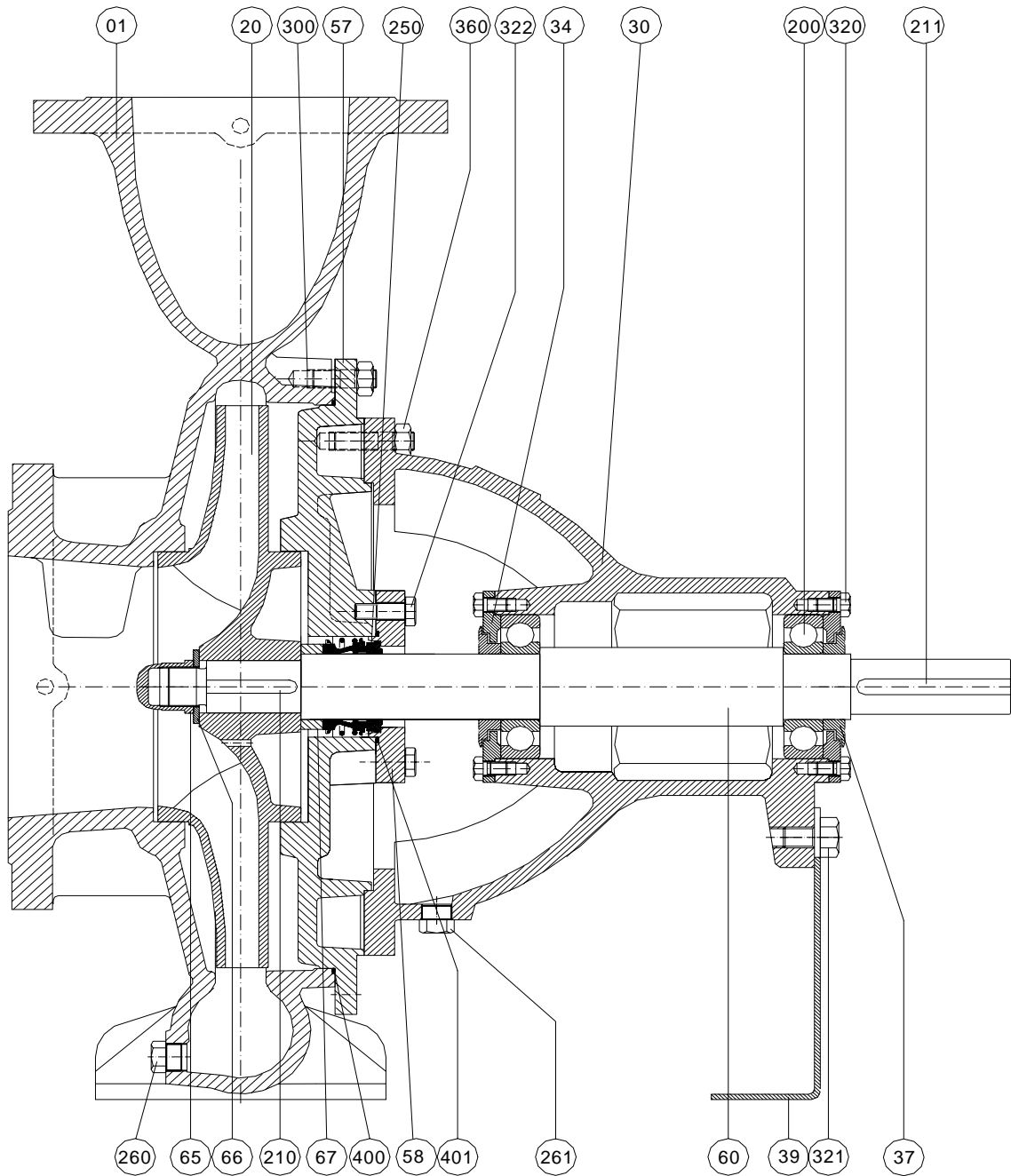

PART NO	PART NAME	PART NO	PART NAME
01	Pump Casing	210	Impeller Key
20	Impeller	211	Coupling Key
30	Bearing Housing	250	Mechanical Seal
34	Bearing Housing Cover	260	Drain Plug
39	Supporting Foot	261	Plug
37	Lip Seal	300	Stud
57	Stuffing Box	320	Hexagonal Bolt
58	Mech. Seal Cover	321	Hexagonal Bolt
60	Pump Shaft	322	Hexagonal Bolt
65	Impeller Nut	360	Hexagonal Nut
66	Ring	400	O-Ring
67	Mech. Seal Front Ring	401	O-Ring
200	Ball Bearing		

NM End Suction Centrifugal Pumps

Technical Data

Bearings, Stuffing-Box, Mechanical Seal

Group	Bearing System	Stuffing Box			Mechanical Seal Diameter	Pump Size
	Type of Bearing	Shaft $\varnothing d_1$	Packing Ring Size $\varnothing D \times \varnothing d \times T$	Qty		
A	2 x 6306 2RS-C3	$\varnothing 30$	$\varnothing 46 \times \varnothing 30 \times 45$	3 Soft Packing + 1 Lantern Ring	$\varnothing 30$	32-160, 40-160, 50-160, 65-160, 80-160, 100-160, 32-200, 40-200, 50-200, 65-200, 32-250, 40-250, 50-250
B	2 x 6308 2RS-C3	$\varnothing 40$	$\varnothing 60 \times \varnothing 40 \times 55.5$	3 Soft Packing + 1 Lantern Ring	$\varnothing 40$	80-200, 100-200, 125-200, 150-200, 65-250, 80-250, 100-250, 125-250, 150-250, 50-315, 65-315, 80-315, 100-315, 65-400
C	2 x 6310 2RS-C3	$\varnothing 50$	$\varnothing 70 \times \varnothing 50 \times 55$	3 Soft Packing + 1 Lantern Ring	$\varnothing 50$	200-280, 125-315, 150-315, 200-315, 80-400, 100-400, 125-400, 150-400
D	2 x 6312 2RS-C3	$\varnothing 60$	$\varnothing 85 \times \varnothing 60 \times 82$	3 Soft Packing + 1 Lantern Ring	$\varnothing 60$	250-315, 200-400, 150-500, 300, 315
E	NU 314 2 x 7314	$\varnothing 75$	$\varnothing 107,5 \times \varnothing 75 \times 115,5$	5 Soft Packing + 1 Lantern Ring	$\varnothing 75$	250-400, 300-400, 200-500, 250-500, 350-450

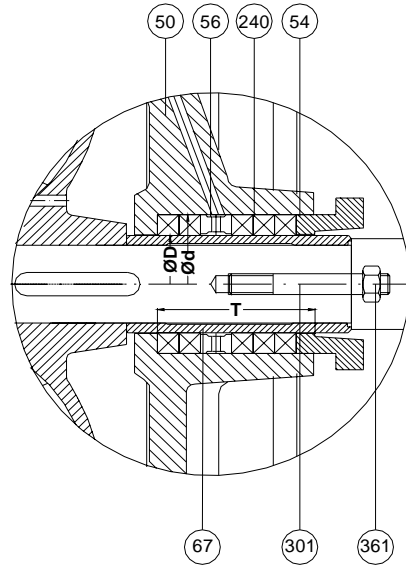
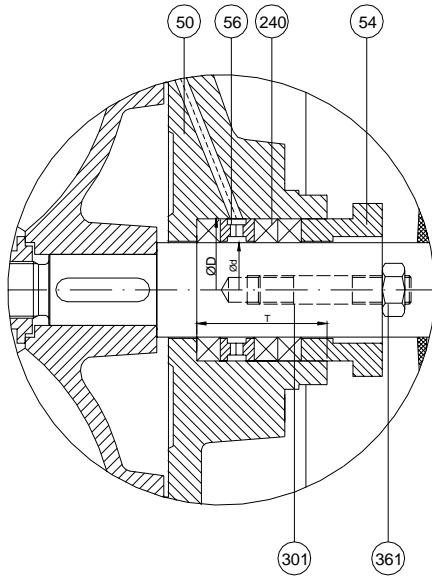

Part No	Part Name
50	Stuffing Box
54	Glen
56	Lantern Ring
240	Gland
301	Stud for Gland
361	Nut for Gland

Part No	Part Name
50	Stuffing Box
54	Glen
56	Lantern Ring
67	Seal Sleeve
240	Gland
301	Stud for Gland
361	Nut for Gland

NM End Suction Centrifugal Pumps

Mechanical Seal Applications

BURGMANN M7N-M74N-M78N

- Single Seal
- Unbalanced
- Independent of direction of rotation
- To EN 12756

p ₁	: 16 Bar
t	: -50...220 °C
V _g	: 20 m/s

Axial Movement

d1 ≤ 25	: ±1,0 mm
28 ≤ d1 ≤ 63	: ±1,5 mm
D1 ≥ 65	: ± 2,0 mm

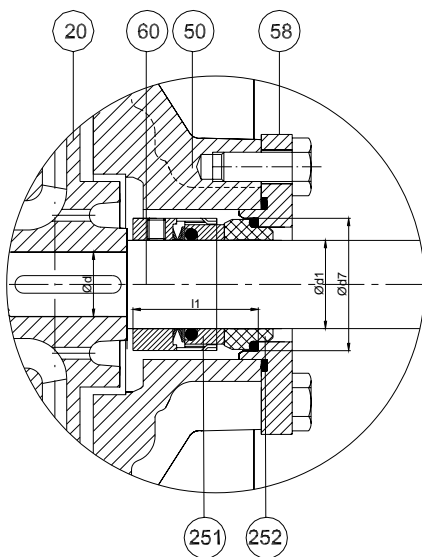

Part No	Part Name for A, B, C, D
20	Impeller
50	Mechanical Seal Box
58	Mechanical Seal Box Cover
251	Rotating Part of Mechanical Seal
252	Stationary Part of Mechanical Seal

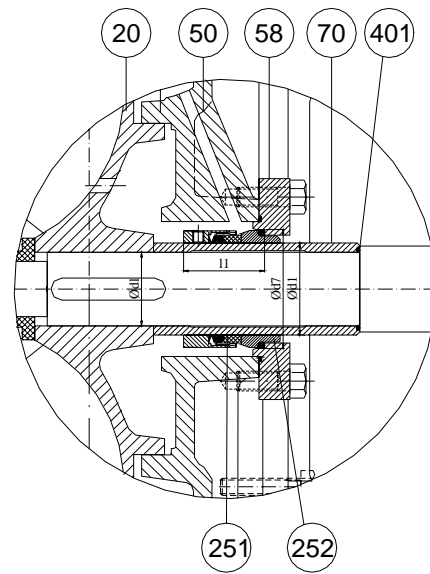

Part No	Part Name for E
20	Impeller
50	Mechanical Seal Box
58	Mechanical Seal Box Cover
70	Seal Sleeve
251	Rotating Part of Mechanical Seal
252	Rotating Part of Mechanical Seal
401	Seal Sleeve O-Ring

Group	Pump Size	Ø d1	Ø d7	Ø d1	l1=l1k
A	32-160, 40-160, 50-160, 65-160, 80-160, 100-160, 32-200, 40-200, 50-200, 65-200, 32-250, 40-250, 50-250	Ø 30	Ø 45	Ø 22	42,5
B	80-200, 100-200, 125-200, 150-200, 65-250, 80-250, 100-250, 125-250, 150-250, 50-315, 65-315, 80-315, 100-315, 65-400	Ø 40	Ø 58	Ø 30	45
C	200-280, 125-315, 150-315, 200-315, 80-400, 100-400, 125-400, 150-400	Ø 50	Ø 70	Ø 40	47,5
D	250-315, 200-400, 150-500, 300-315	Ø 60	Ø 80	Ø 50	52,5
E	250-400, 300-400, 200-500, 250-500, 350-450	Ø 75	Ø 97	Ø 60	60

NM End Suction Centrifugal Pumps

Mechanical Seal Applications

BURGMANN M3N-M32N-M37N-M37GN

- Single Seal
- Unbalanced
- Conical Spring
- Dependent on direction of rotation
- To EN 12756

p ₁	: 10 Bar
t	: -20...180 °C
V _g	: 10 m/s
Axial Movement	: ±1,0 mm

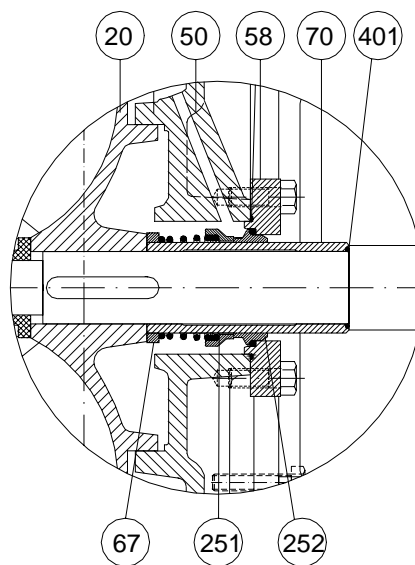
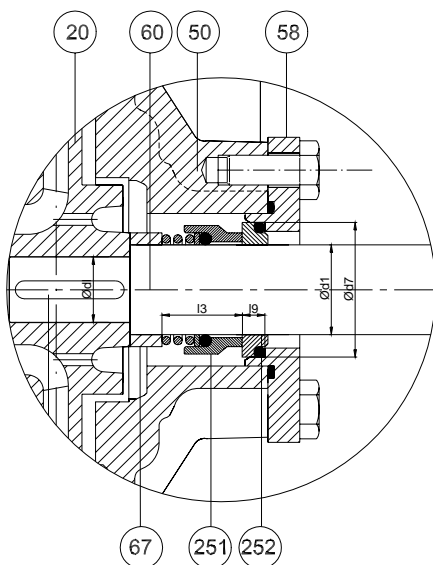

Part No	Part Name for A, B, C, D
20	Impeller
50	Mechanical Seal Box
58	Mechanical Seal Box Cover
67	Adjusting Ring
251	Rotating Part of Mechanical Seal
252	Stationary Part of Mechanical Seal

Part No	Part Name for E
20	Impeller
50	Mechanical Seal Box
58	Mechanical Seal Box Cover
67	Adjusting Ring
70	Seal Sleeve
251	Rotating Part of Mechanical Seal
252	Rotating Part of Mechanical Seal
401	Seal Sleeve O-Ring

Group	Pump Size	Ø d1	Ø d7	Ø dl	l3	l9
A	32-160, 40-160, 50-160, 65-160, 80-160, 100-160, 32-200, 40-200, 50-200, 65-200, 32-250, 40-250, 50-250	Ø 30	Ø 45	Ø 22	26,5	11,5
B	80-200, 100-200, 125-200, 150-200, 65-250, 80-250, 100-250, 125-250, 150-250, 50-315, 65-315, 80-315, 100-315, 65-400	Ø 40	Ø 58	Ø 30	36	14
C	200-280, 125-315, 150-315, 200-315, 80-400, 100-400, 125-400, 150-400	Ø 50	Ø 70	Ø 40	47,5	47,5
D	250-315, 200-400, 150-500, 300-315	Ø 60	Ø 80	Ø 50	45	15
E	250-400, 300-400, 200-500, 250-500, 350-450	Ø 75	Ø 97	Ø 60	62	18

NM End Suction Centrifugal Pumps

Mechanical Seal Applications

BURGMANN HJ92N-HJ977N-SHJ97G

- Single Seal
- Unbalanced
- Product Protected Spring
- Independent on Direction of Rotation
- To EN 12756

p_1	: 0.8...25 Bar
t (HJ92N)	: -50...220 °C
t (HJ977N)	: -20...180 °C
V_g	: 10 m/s
Axial Movement	: $\pm 0,5$ mm

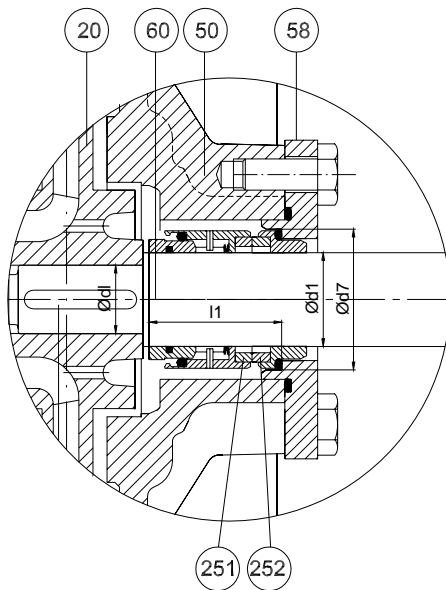

Part No	Part Name for A, B, C, D
20	Impeller
50	Mechanical Seal Box
58	Mechanical Seal Box Cover
251	Rotating Part of Mechanical Seal
252	Stationary Part of Mechanical Seal

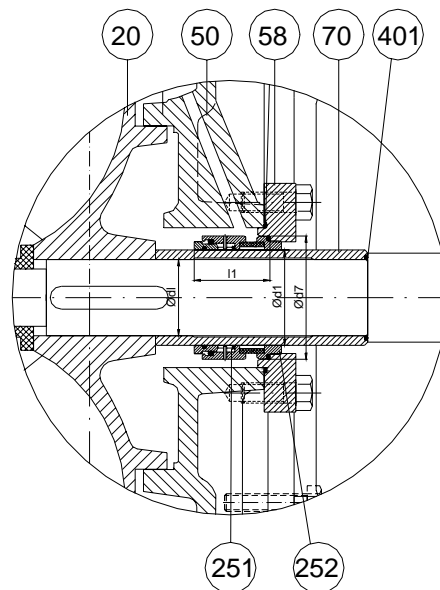

Part No	Part Name for E
20	Impeller
50	Mechanical Seal Box
58	Mechanical Seal Box Cover
67	Adjusting Ring
70	Seal Sleeve
251	Rotating Part of Mechanical Seal
252	Rotating Part of Mechanical Seal
401	Seal Sleeve O-Ring

Group	Pump Size	$\varnothing d_1$	$\varnothing d_7$	$\varnothing d_1$	l_1
A	32-160, 40-160, 50-160, 65-160, 80-160, 100-160, 32-200, 40-200, 50-200, 65-200, 32-250, 40-250, 50-250	$\varnothing 30$	$\varnothing 45$	$\varnothing 22$	42,5
B	80-200, 100-200, 125-200, 150-200, 65-250, 80-250, 100-250, 125-250, 150-250, 50-315, 65-315, 80-315, 100-315, 65-400	$\varnothing 40$	$\varnothing 58$	$\varnothing 30$	45
C	200-280, 125-315, 150-315, 200-315, 80-400, 100-400, 125-400, 150-400	$\varnothing 50$	$\varnothing 70$	$\varnothing 40$	47,5
D	250-315, 200-400, 150-500, 300-315	$\varnothing 60$	$\varnothing 80$	$\varnothing 50$	52,5
E	250-400, 300-400, 200-500, 250-500, 350-450	$\varnothing 75$	$\varnothing 97$	$\varnothing 60$	60

NM End Suction Centrifugal Pumps

Mechanical Seal Applications

BURGMANN MG1

- Single Seal
- Unbalanced
- Elastomer Bellows
- Independent on Direction of Rotation

p ₁	: 12 Bar
t	: -20...120 °C
V _g	: 10 m/s

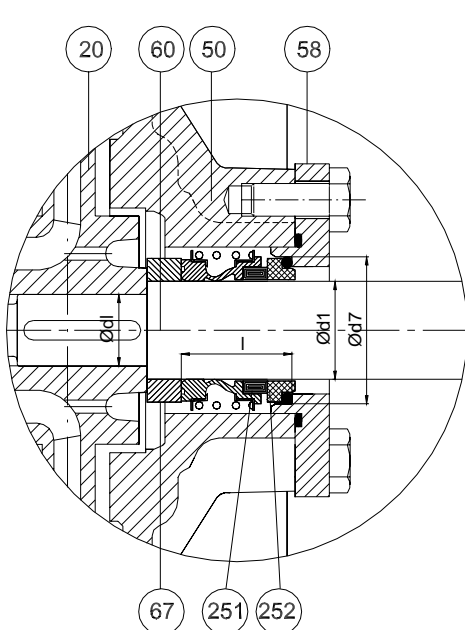

Part No	Part Name for A, B, C, D
20	Impeller
50	Mechanical Seal Box
58	Mechanical Seal Box Cover
67	Adjusting Ring
251	Rotating Part of Mechanical Seal
252	Stationary Part of Mechanical Seal

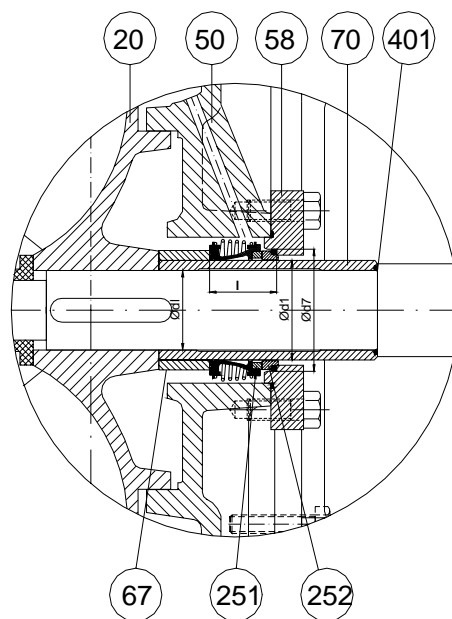

Part No	Part Name for E
20	Impeller
50	Mechanical Seal Box
58	Mechanical Seal Box Cover
67	Adjusting Ring
70	Seal Sleeve
251	Rotating Part of Mechanical Seal
252	Rotating Part of Mechanical Seal
401	Seal Sleeve O-Ring

Group	Pump Size	Ø d1	Ø d7	Ø dl	l
A	32-160, 40-160, 50-160, 65-160, 80-160, 100-160, 32-200, 40-200, 50-200, 65-200, 32-250, 40-250, 50-250	Ø 30	Ø 45	Ø 22	34
B	80-200, 100-200, 125-200, 150-200, 65-250, 80-250, 100-250, 125-250, 150-250, 50-315, 65-315, 80-315, 100-315, 65-400	Ø 40	Ø 58	Ø 30	39
C	200-280, 125-315, 150-315, 200-315, 80-400, 100-400, 125-400, 150-400	Ø 50	Ø 70	Ø 40	40
D	250-315, 200-400, 150-500, 300-315	Ø 60	Ø 80	Ø 50	49
E	250-400, 300-400, 200-500, 250-500, 350-450	Ø 75	Ø 97	Ø 60	51,3

NM End Suction Centrifugal Pumps

Mechanical Seal Applications

BURGMANN BT-AR

- Single Seal
- Unbalanced
- Rubber Bellows
- Independent on Direction of Rotation

p ₁	: 6 Bar
t	: -20...120 °C
V _g	: 10 m/s

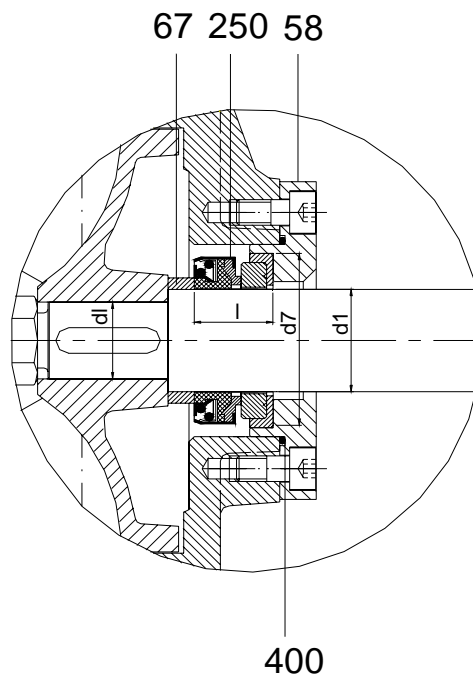

Part No	Part Name for A, B, C, D
58	Mechanical Seal Box Cover
67	Adjusting Ring
251	Mechanical Seal
400	O-Ring for Cover

Group	Pump Size	Ø d1	Ø d7	Ø dI	l
A	32-160, 40-160, 50-160, 65-160, 80-160, 100-160, 32-200, 40-200, 50-200, 65-200, 32-250, 40-250, 50-250	Ø 30	Ø 57	Ø 22	25
B	80-200, 100-200, 125-200, 150-200, 65-250, 80-250, 100-250, 125-250, 150-250, 50-315, 65-315, 80-315, 100-315, 65-400	Ø 40	Ø 68	Ø 30	30
C	200-280, 125-315, 150-315, 200-315, 80-400, 100-400, 125-400, 150-400	Ø 50	Ø 88	Ø 40	38
D	250-315, 200-400, 150-500, 300-315	Ø 60	Ø 110	Ø 50	45

NM End Suction Centrifugal Pumps

Mechanical Seal Applications

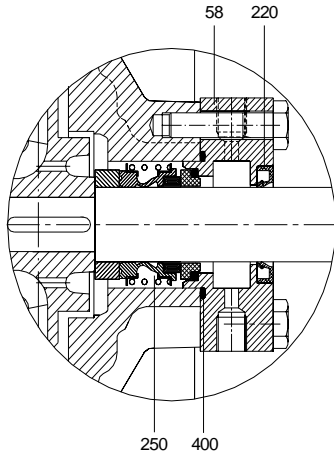

QUENCHING

A quench is used on the one hand when a single mechanical seal does not function at all or only within certain limits without auxiliary measures or when a double mechanical seal with pressurized buffer medium is unnecessary. When an integral stationary seat stop is fitted, the quench pressure should not exceed 1 Bar.

- ❖ Absorption or removal of leakage by quench medium.
- ❖ Monitoring of the mechanical seal's leakage rate by periodic measurement of the level of the quench medium in the circulation vessel or thermosyphon vessel.
- ❖ Lubrication and cooling of the stand-by mechanical seal.
- ❖ Exclusion of the air: For media reacting with atmospheric oxygen the quenching medium stops the leakage making contact with air.

58	Mech. Seal Cover for Quenching
220	Oil Seal
250	Mechanical Seal
400	O-Ring For the Cover

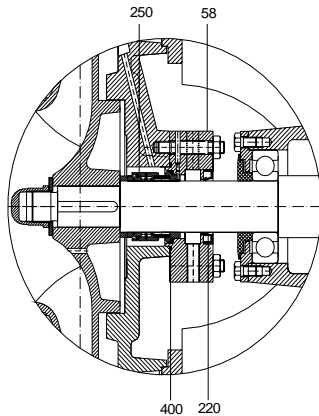

QUENCH WITH AN INTERNAL CIRCULATION

A pumped medium is injected into the area of the sliding faces from the discharge of the pumps.

58	Mech. Seal Cover
220	Oil Seal
250	Mechanical Seal
400	O-Ring For the Cover

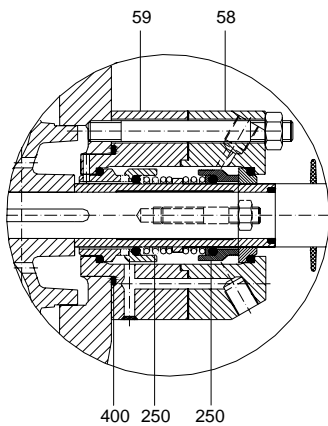

DOUBLE MECHANICAL SEAL APPLICATION

58	Mech. Seal Cover
59	Mech. Seal Cover
250	Mechanical Seal
400	O-Ring For the Cover

For these applications please consult to representative.

NM End Suction Centrifugal Pumps

Technical Data

Temperature and Pressure Limits

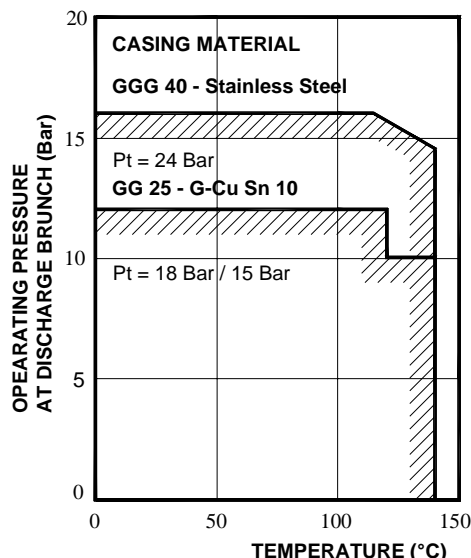

Pt: Test Pressure

Casing Material	Temperature of Liquid	Max. Permissible Casing Pressure
Cast Iron GG 25 and Bronze G-CuSn 10	Up to 120 °C	12 Bar
	Up to 140 °C	10 Bar
Spheroidal Cast Iron GGG 40 and Stainless Steel AISI 304-316	Up to 120 °C	16 Bar
	Up to 140 °C	14 Bar

Material Options

Components	Material. No						
		0.6025	0.7040	2.1050.01	1.4021	1.4301	1.4401
Pump Casing		●	○	○		○	○
Back Cover		●	○	○		○	○
Impeller		●	○	○		○	○
Gland		○	●	○		○	○
Wearing Ring*		○	○	●		○	○
Shaft					●	○	○
Shaft Sleeve					●	○	○
Bearing Housing		●	○	○		○	○
Bearing Cover		●	○	○		○	○

● - Standard Manufacturing
○ - Optional

Material Equivalent

Description	DIN 17007	EN-DIN	ASTM
Cast Iron	0.6025	GJL-250 (GG25)	A 48 Class 40-B
Nodular Cast Iron	0.7040	GJS-400-15 (GGG40)	A 536 Gr.60-40-18
Cast Bronze	2.1050.01	G-Cu Sn 10	B 584 C 90700
Chrome Steel	1.4021	X20 Cr 13	A 276 Type 420
Chrome Nickel Steel	1.4301	X5 Cr Ni 18.9	A 276 Type 304
Chrome Nickel Molybdenum Steel	1.4401	X5 Cr Ni Mo 18.10	A 276 Type 316

* Wearing Rings and Shaft Sleeves are upon request.

NM End Suction Centrifugal Pumps

Technical Data

Key-Way and Shaft Dimensions for Motor Side

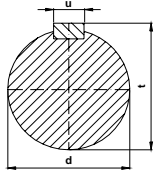

Group	d	t	u
A	24	28	8
B	32	37	10
C	42	47	12
D	55	61	16
E	65	72	18

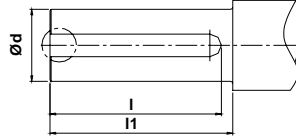

l	l1
50	47
75	80
106	110
100	110
125	140

Key-Way and Shaft Dimensions for Impeller Side

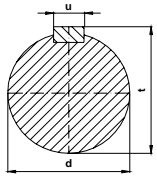

Group	d	t	u
A	22	26	6
B	30	34	8
C	40	45	10
D	50	55,5	14
E	60	67	18

NM End Suction Centrifugal Pumps

Technical Data

NM-Cr

In this application, both Stuffing Box (Back Cover) and Pump Casing are stainless steel. Also, pump discharge flange can be rotated by 90° to other positions by the help of modular pump model.

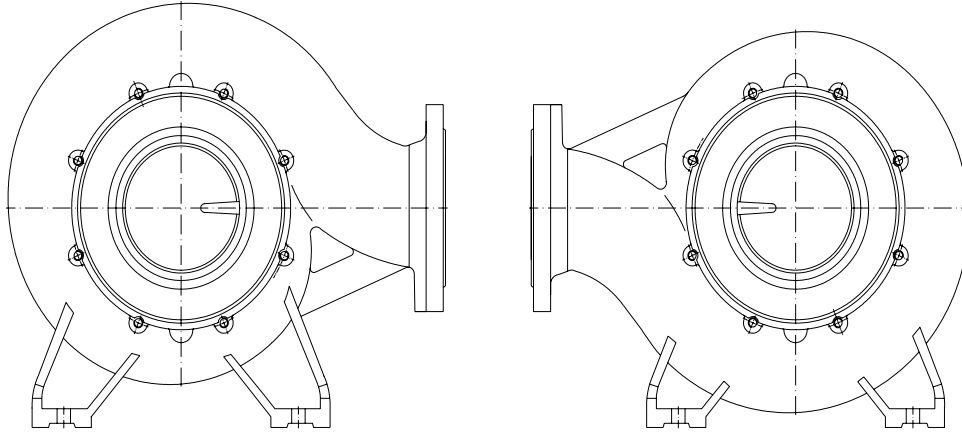

Components \ Material. No	Material. No						
	0.6025	0.7040	2.1050.01	1.4021	1.4301	1.4401	
Pump Casing					0	●	
Back Cover					0	●	
Impeller					0	●	
Gland					0	●	
Wearing Ring*					0	●	
Shaft				●	0	0	
Shaft Sleeve				●	0	0	
Bearing Housing	●				0	0	
Bearing Cover	●				0	0	

NM-CR PUMP TYPES	NM-CR PUMP TYPES	NM-CR PUMP TYPES
NM-CR 32-200	NM-CR 50-250	NM-CR 150-315
NM-CR 40-200	NM-CR 80-250	
NM-CR 50-200	NM-CR 100-250	
NM-CR 65-200	NM-CR 125-250	
NM-CR 80-200	NM-CR 150-250	
NM-CR 100-200		
NM-CR 125-200		

NM End Suction Centrifugal Pumps

Flange Dimensions

PUMP SUCTION AND DISCHARGE FLANGE DIMENSIONS								
DNs	PN	ØD	Øk	Ød4	Ød2	b	f	Hole
DNd								Number
32	16	140	100	78	18	18	2	4
40		150	110	88	18	18	3	4
50		165	125	102	18	20	3	4
65		185	45	122	18	20	3	4
80		200	160	138	18	22	3	8
100		220	180	158	18	24	3	8
125		250	210	188	18	26	3	8
150		285	240	212	22	26	3	8
200		340	295	268	22	30	3	12
250		395	350	320	22	28	3	12
300	10	445	400	370	22	28	4	12
350		505	460	430	22	34	4	16
400		565	515	482	26	34	4	16

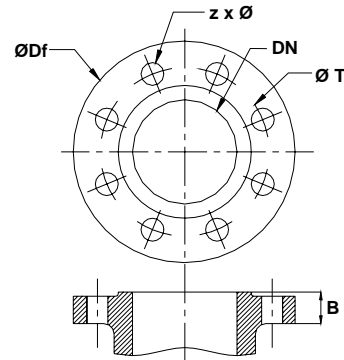

No	Pump Type	Flanges				
		DNs (mm) Suction		DNd (MM) Discharge		
1	32-160	50	PN 16	32	PN 16	
2	32-200					
3	32-250					
4	40-160	65		80		40
5	40-200					
6	40-250					
7	50-160	65		80		50
8	50-200					
9	50-250					
10	50-315					
11	65-160					
12	65-200	80	100	65		
13	65-250					
14	65-315					
15	65-400					
16	80-160	100	125	80		
17	80-200					
18	80-250					
19	80-315					
20	80-400					
21	100-160				125	150
22	100-200					
23	100-250					
24	100-315					
25	100-400					
26	125-200	150	200	125		
27	125-250					
28	125-315					
29	125-400					
30	150-200	200	250	150		
31	150-250					
32	150-315					
33	150-400					
34	150-500					
35	200-280				250	300
36	200-315					
37	200-400					
38	200-500					
39	250-315	300	350	250		
40	250-400					
41	250-500					
42	250-500A					
43	300-315A					
44	300-315	350	400	300		
45	300-400					
46	350-450	400	350	350		

NM End Suction Centrifugal Pumps

Overall Dimensions

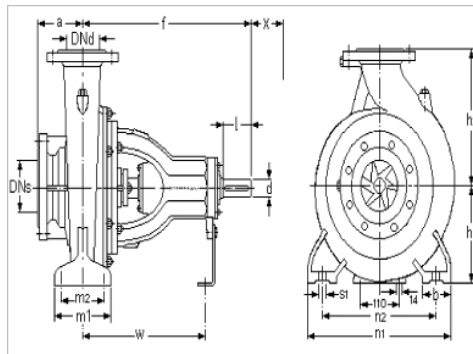

No	PUMP Size		Nozles		Lenght		Height		Pump Feet Fixing Details						Shaft End			(*) X mm	Weight kg
	DIN 24255	Added	DNs mm	DNd mm	a mm	f mm	h1 mm	h2 mm	b mm	m1 mm	m2 mm	n1 mm	n2 mm	s1 mm	W mm	d mm	l mm		
1	32-160		50	32	80	360	132	160	50	100	70	240	190	M12	260	24	50	65	37
2	32-200		50	32	80	360	160	180	50	100	70	240	190	M12	260	24	50	65	40
3		32-250	50	32	100	360	180	225	65	125	95	320	250	M12	260	24	50	80	45
4	40-160		65	40	80	360	132	160	50	100	70	240	190	M12	260	24	50	75	38
5	40-200		65	40	100	360	160	180	50	100	70	265	212	M12	260	24	50	75	44.5
6	40-250		65	40	100	360	180	225	65	125	95	320	250	M12	260	24	50	75	54
7	50-160		65	50	100	360	160	180	50	100	70	265	212	M12	260	24	50	80	41.5
8	50-200		65	50	100	360	160	200	50	100	70	265	212	M12	260	24	50	85	46.5
9	50-250		65	50	100	360	180	225	65	125	95	320	250	M12	260	24	50	85	54.5
10		50-315	80	50	100	470	225	280	80	160	120	360	280	M16	330	32	80	100	103
11	65-160		80	65	100	360	160	200	65	125	95	280	212	M12	260	24	50	100	44
12	65-200		80	65	100	360	180	225	65	125	95	320	250	M12	260	24	50	100	47.5
13	65-250		80	65	100	470	200	250	80	160	120	360	280	M16	340	32	80	100	77.5
14	65-315		80	65	125	470	225	280	80	160	120	400	315	M16	340	32	80	110	92
15		65-400	100	65	125	470	250	355	80	160	120	400	315	M16	340	32	80	110	125
16	80-160		100	80	125	360	180	225	65	125	95	320	250	M12	260	24	50	110	51
17	80-200		100	80	125	470	180	250	65	125	95	345	280	M12	340	32	80	110	75.5
18	80-250		100	80	125	470	200	280	80	160	120	400	315	M16	340	32	80	115	93
19	80-315		100	80	125	470	250	315	80	160	120	400	315	M16	340	32	80	120	107
20		80-400	100	80	125	530	280	355	100	200	150	500	400	M20	370	42	110	120	162
21		100-160	125	100	125	360	200	280	80	160	1200	360	280	M16	260	24	50	120	70
22	100-200		125	100	125	470	200	280	80	160	120	360	280	M16	340	32	80	120	83
23	100-250		125	100	140	470	225	280	80	160	120	400	315	M16	340	32	80	130	95
24	100-315		125	100	140	470	250	315	80	160	120	400	315	M16	340	32	80	130	110
25	100-400		125	100	140	530	280	355	100	200	150	500	400	M20	370	42	110	130	168
26		125-200	150	125	140	470	250	315	80	160	120	400	315	M16	340	32	80	130	106.5
27	125-250		150	125	140	470	250	355	80	160	120	400	315	M16	340	32	80	140	105.5
28	125-315		150	125	140	530	280	355	100	200	150	500	400	M20	370	42	110	140	166.5
29	125-400		150	125	140	530	315	400	100	200	150	500	400	M20	370	42	110	140	189
30		150-200	200	150	160	470	280	355	100	200	150	500	400	M16	340	32	80	170	137.5
31		150-250	200	150	160	470	280	375	100	200	150	500	400	M16	340	32	80	140	137.5
32	150-315		200	150	160	530	280	400	100	200	150	550	450	M20	370	42	110	140	182.5
33	150-400		200	150	160	530	315	450	100	200	150	550	450	M20	370	42	110	140	210.5
34		150-500	200	150	180	700	400	525	110	250	200	620	500	M20	500	55	110	140	197
35		200-280	250	200	200	560	355	450	110	250	200	620	500	M20	410	42	110	200	300
36		200-315	250	200	180	535	355	450	110	250	200	620	500	M20	410	42	110	160	201
37		200-400	250	200	180	710	400	500	110	250	200	620	500	M20	500	55	110	160	354
38		200-500	250	200	210	850	400	550	140	300	240	720	600	M24	600	65	140	160	520
39		250-315	300	250	240	725	400	525	140	300	240	620	500	M24	500	55	110	200	419
40		250-400	300	250	225	865	400	550	140	300	240	620	500	M24	600	65	140	200	510
41		250-500	300	250	280	875	500	700	150	360	290	900	750	M28	560	65	140	320	615
42		250-500A	300	250	225	865	450	630	160	300	240	720	600	M24	600	65	140	200	615
43	980 RPM	300-315A	300	300	275	760	425	600	140	300	240	620	500	M24	550	55	140	270	516
44	1500 RPM	300-315	300	300	275	810	425	600	140	300	240	620	500	M24	550	55	140	270	516
45		300-400	350	300	275	865	450	630	150	360	290	800	650	M24	550	65	140	300	636
46		350-450	400	350	280	875	500	700	150	360	290	900	750	M24	560	65	140	300	755

NM End Suction Centrifugal Pumps

Performance Curves 50 Hz

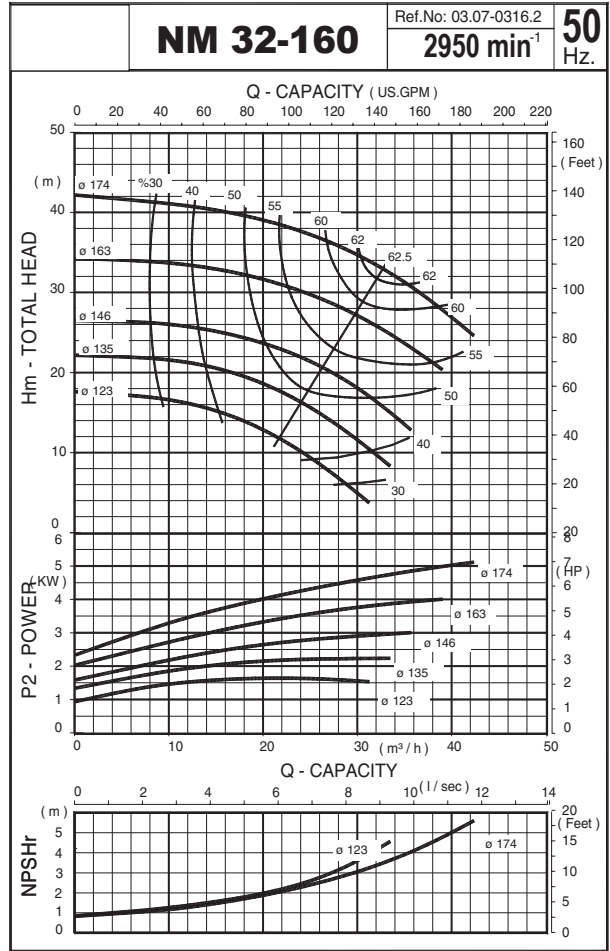
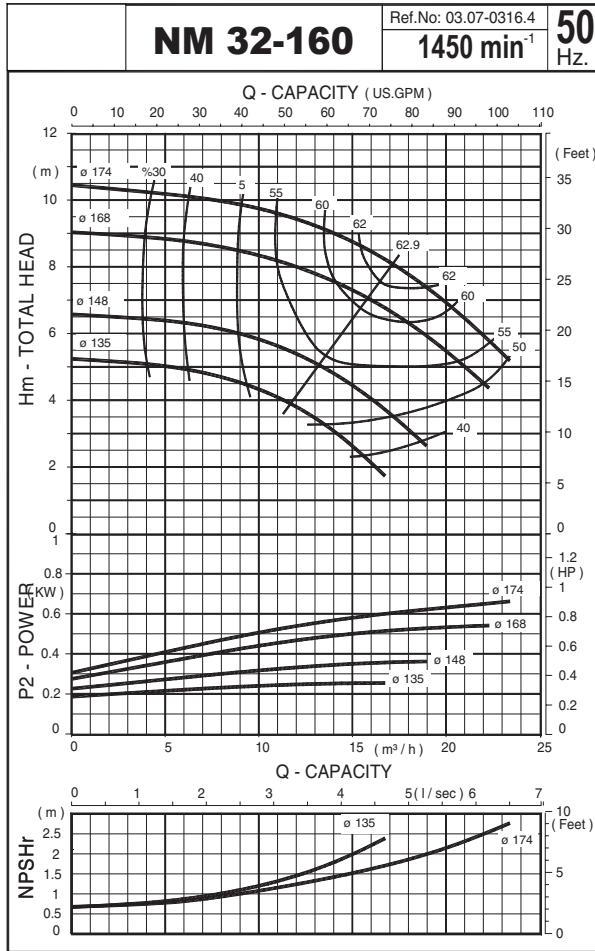

The Performance Curves 50 Hz are based on the kinematic viscosity 1 mm²/s and density 1g/cm³. Tolerances are acc. to ISO 9906 Annex A.

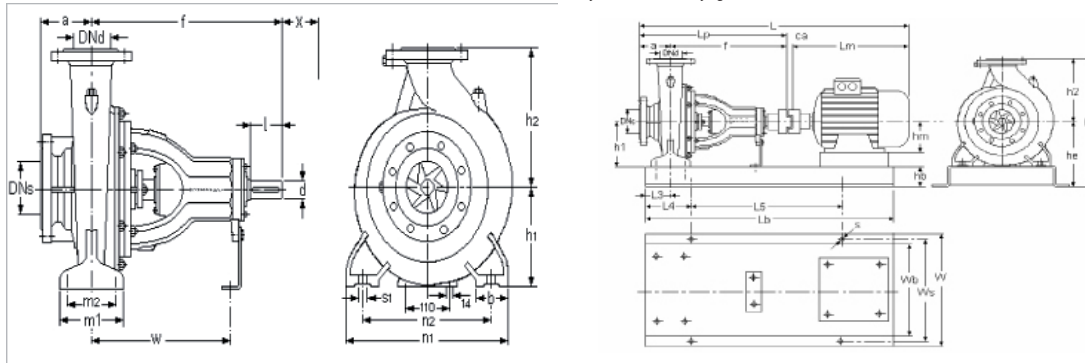

Pump size	Flanges		Length		Height		Mounting details							Shaft end		(*) X mm	Weight kg
	DNs mm	DNd mm	a mm	f mm	h1 mm	h2 mm	b mm	m1 mm	m2 mm	n1 mm	n2 mm	s1 mm	W mm	d mm	l mm		
32-160	50	32	80	360	132	160	50	100	70	240	190	M12	260	24	50	65	37

	MOTOR			PUMP		GENERAL				BASEPLATE									
	KW	IEC	Lm mm	Hm mm	Lp mm	Ca mm	L mm	W mm	H mm	Lb mm	Wb mm	Hb mm	He mm	L3 mm	L4 mm	L5 mm	Ws mm	S mm	Plate No
32-160 4poles 50Hz	0,25	71	242	71	440	16	698	330	357	630	240	65	197	60	105	420	290	19	2.01
	0,37	71	242	71	440	16	698	330	357	630	240	65	197	60	105	420	290	19	2.01
	0,55	80	273	80	440	16	729	330	357	710	240	65	197	60	115	480	290	19	2.02
	0,75	80	273	80	440	16	729	330	357	710	240	65	197	60	115	480	290	19	2.02
32-160 2poles 50Hz	1,1	80	273	80	440	16	729	330	357	710	240	65	197	60	115	480	290	19	2.02
	1,5	90S	300	90	440	16	756	330	357	710	240	65	197	60	115	480	290	19	2.02
	2,2	90L	325	90	440	20	785	330	357	710	240	65	197	60	115	480	290	19	2.02
	3	100L	365	100	440	20	825	330	357	800	240	65	197	60	130	540	290	19	2.03
	4	112M	385	112	440	20	844	330	357	800	240	65	197	60	130	540	290	19	2.03
	5,5	132S	455	132	440	21	916	360	357	800	270	65	197	60	130	540	320	19	3.03

NM End Suction Centrifugal Pumps

Performance Curves 50 Hz

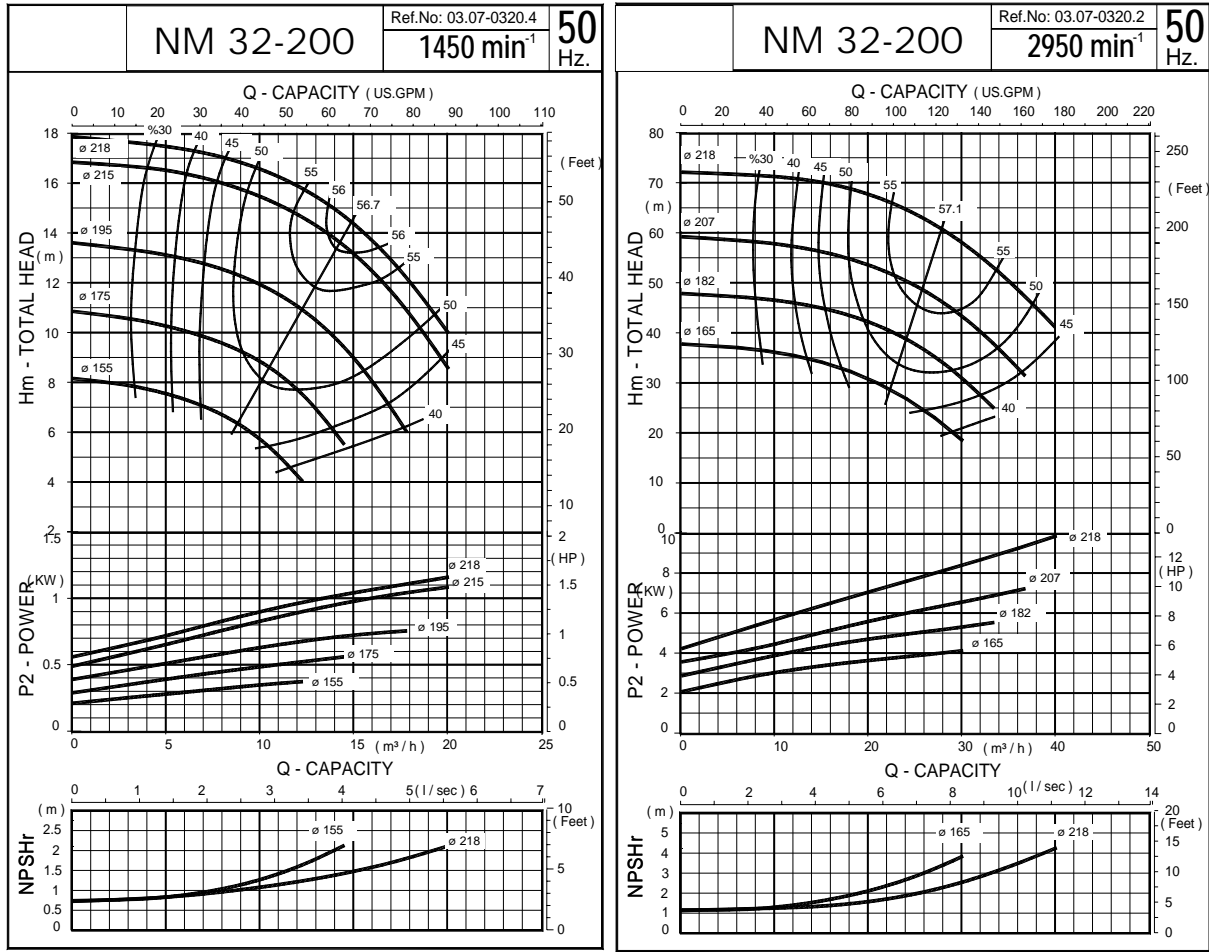

The Performance Curves 50 Hz are based on the kinematic viscosity 1 mm²/s and density 1g/cm³. Tolerances are acc. to ISO 9906 Annex A.

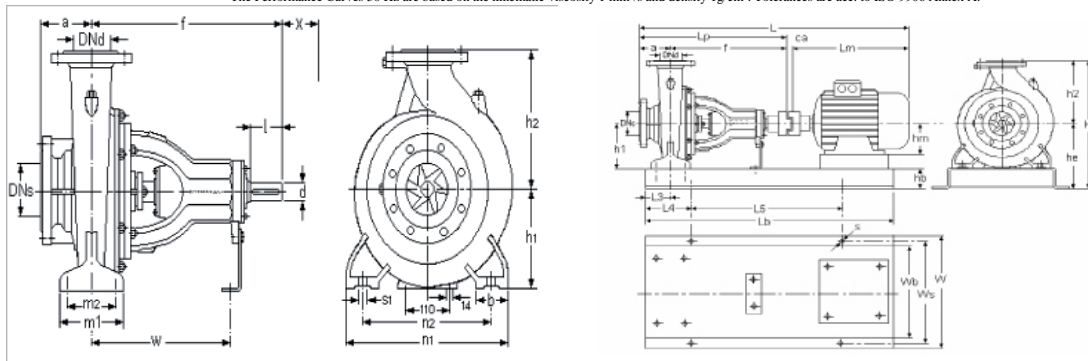

Pump size	Flanges		Length		Height		Mounting details							Shaft end		(*) X mm	Weight kg
	DNs mm	DNd mm	a mm	f mm	h1 mm	h2 mm	b mm	m1 mm	m2 mm	n1 mm	n2 mm	s1 mm	W mm	d mm	l mm		
32-200	50	32	80	360	160	180	50	100	70	240	190	M12	260	24	50	65	40

	MOTOR		PUMP		GENERAL					BASEPLATE									
	KW	IEC	Lm mm	Hm mm	Lp mm	Ca mm	L mm	W mm	H mm	Lb mm	Wb mm	Hb mm	He mm	L3 mm	L4 mm	L5 mm	Ws mm	S mm	Plate No
32-200 4 poles 50Hz	0,37	71	242	71	440	16	698	330	405	630	240	65	225	60	105	420	290	19	2,01
	0,55	80	273	80	440	16	729	330	405	710	240	65	225	60	115	480	290	19	2,02
	0,75	80	273	80	440	16	729	330	405	710	240	65	225	60	115	480	290	19	2,02
	1,1	90S	300	90	440	20	760	330	405	710	240	65	225	60	115	480	290	19	2,02
	1,5	90L	325	90	440	20	785	330	405	710	240	65	225	60	115	480	290	19	2,02
32-200 2 poles 50 hz	3	100L	365	100	440	20	825	330	405	800	240	65	225	60	130	540	290	19	2,03
	4	112M	384	112	440	20	844	330	405	800	240	65	225	60	130	540	290	19	2,03
	5,5	132S	455	132	440	21	916	360	405	800	270	65	225	60	130	540	320	19	3,03
	7,5	132S	455	132	440	21	916	360	405	800	270	65	225	60	130	540	320	19	3,03
	11	160M	594	160	440	26	1060	450	420	1000	340	80	240	60	170	660	400	24	5,05

NM End Suction Centrifugal Pumps

Performance Curves 50 Hz

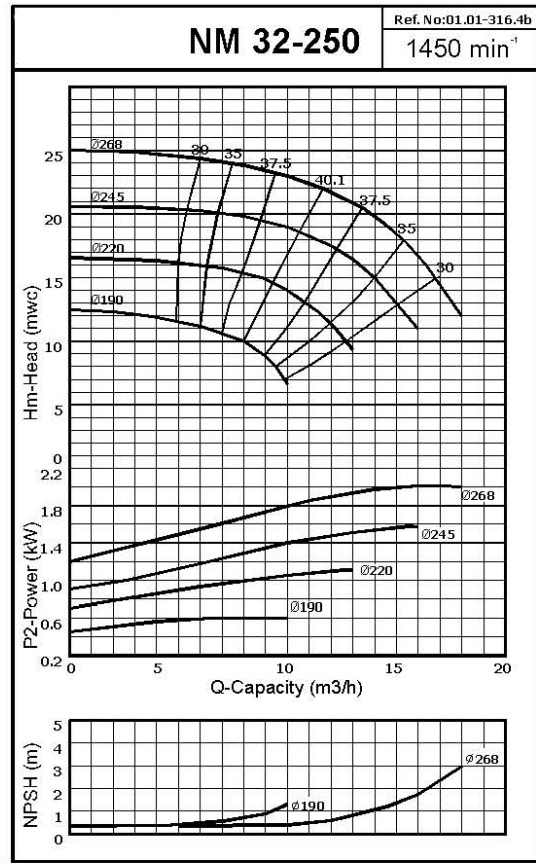
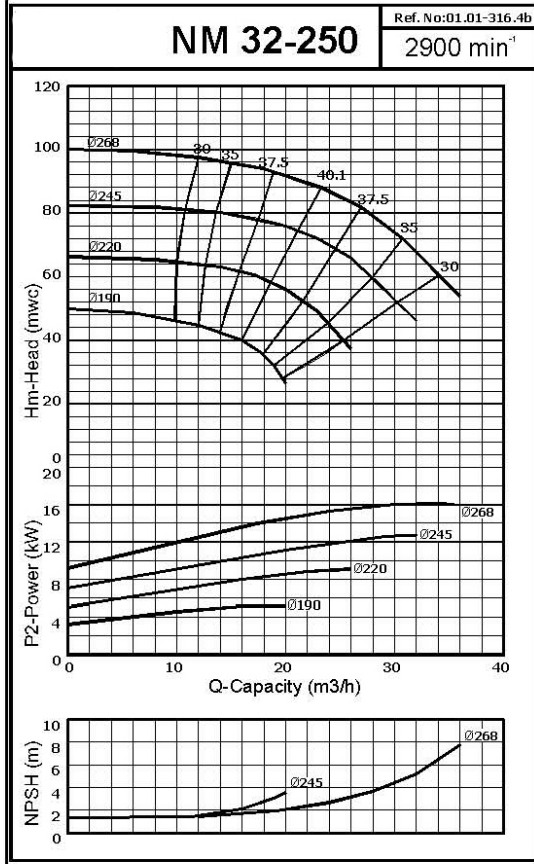

The Performance Curves 50 Hz are based on the kinematic viscosity 1 mm²/s and density 1g/cm³. Tolerances are acc. to ISO 9906 Annex A.

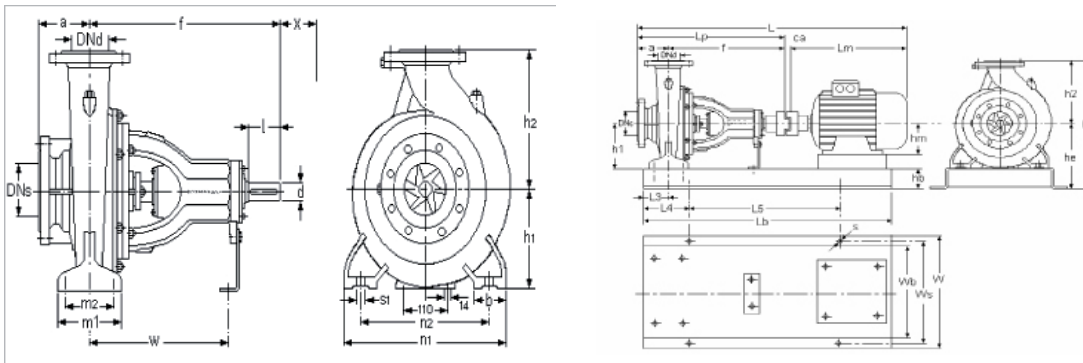

Pump size	Flanges		Length		Height		Mounting details							Shaft end		(*) X mm	Weight kg
	DNs mm	DNd mm	a mm	f mm	h1 mm	h2 mm	b mm	m1 mm	m2 mm	n1 mm	n2 mm	s1 mm	W mm	d mm	l mm		
32-250	50	32	100	360	180	225	50	125	95	320	250	12	260	24	50	80	103

	MOTOR			PUMP		GENERAL				BASEPLATE									
	KW	IEC	Lm mm	Hm mm	Lp mm	Ca mm	L mm	W mm	H mm	Lb mm	Wb mm	Hb mm	He mm	L3 mm	L4 mm	L5 mm	Ws mm	S mm	Plate No
32-250 4poles 50Hz	1.1	90S	300	90	460	20	780	450	485	710	340	80	260	72	115	480	400	24	5,02
	1.5	90L	325	90	460	20	805	450	485	710	340	80	260	72	115	480	400	24	5,02
	2,2	100L	365	100	460	20	845	450	485	800	340	80	260	72	130	540	400	24	5,03
32-250 2poles 50Hz	7.5	132S	455	132	460	21	936	450	485	800	340	80	260	72	130	540	400	24	5,03
	11	160M	594	160	460	26	1080	450	485	1000	340	80	260	72	170	660	400	24	5,05
	15	160M	594	160	460	26	1080	450	485	1000	340	80	260	72	170	660	400	24	5,05
	18,5	160L	638	160	460	30	1128	450	485	1000	340	80	260	72	170	660	400	24	5,05

NM End Suction Centrifugal Pumps

Performance Curves 50 Hz

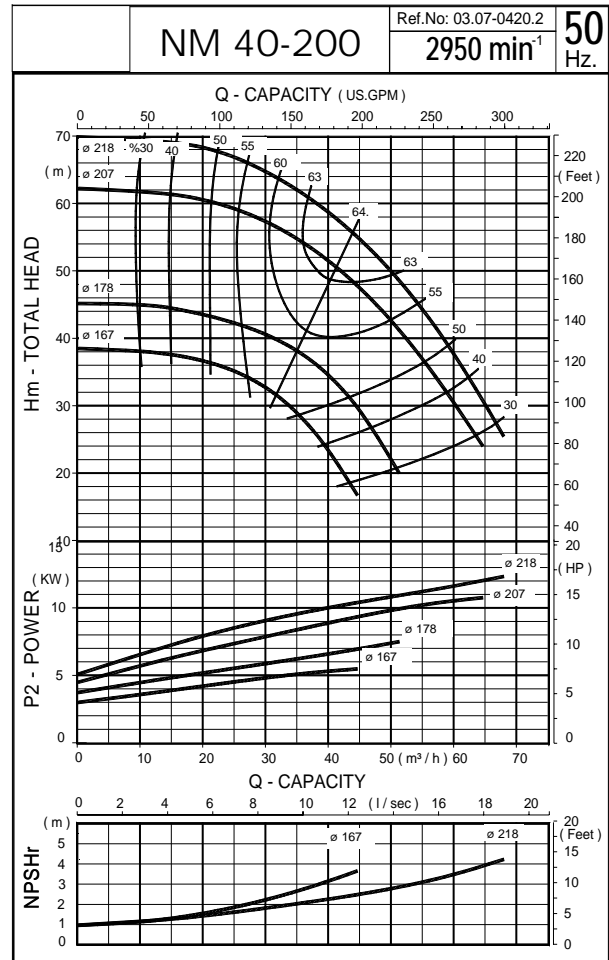
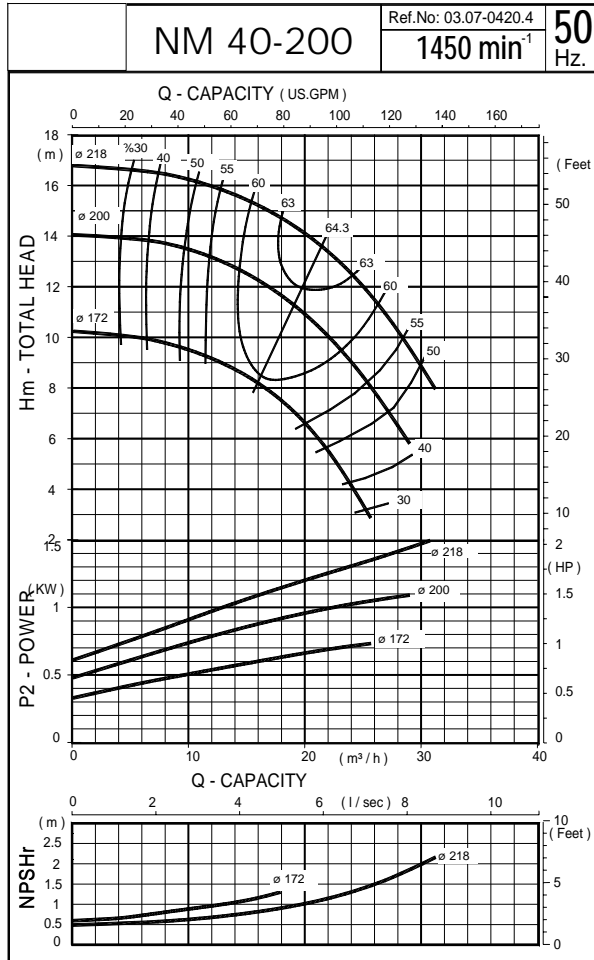

The Performance Curves 50 Hz are based on the kinematic viscosity 1 mm²/s and density 1g/cm³. Tolerances are acc. to ISO 9906 Annex A.

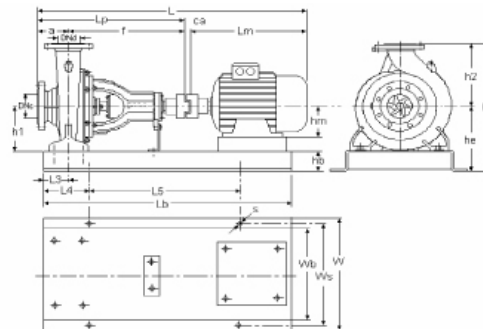
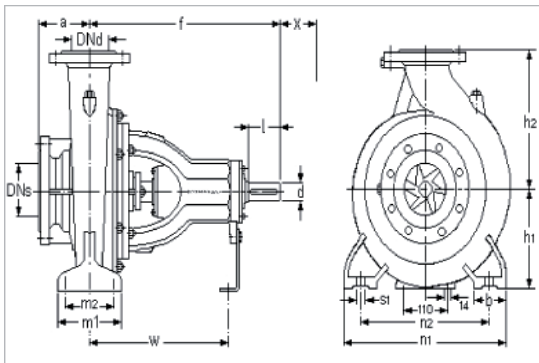

Pump size	Flanges		Length		Height		Mounting details						Shaft end		(*) X mm	Weight kg	
	DNs mm	DNd mm	a mm	f mm	h1 mm	h2 mm	b mm	m1 mm	m2 mm	n1 mm	n2 mm	s1 mm	W mm	d mm			l mm
40-200	65	40	100	360	160	180	50	100	70	265	212	M12	260	24	50	75	44.5

	MOTOR			PUMP			GENERAL				BASEPLATE								
	KW	IEC	Lm mm	Hm mm	Lp mm	Ca mm	L mm	W mm	H mm	Lb mm	Wb mm	Hb mm	He mm	L3 mm	L4 mm	L5 mm	Ws mm	S mm	Plate No
40-200 4poles 50Hz	0.75	80	273	80	460	16	749	360	405	710	270	65	225	60	115	480	320	19	3.02
	1.1	90S	300	90	460	20	780	360	405	710	270	65	225	60	115	480	320	19	3.02
	1.5	90L	325	90	460	20	805	360	405	710	270	65	225	60	115	480	320	19	3.02
40-200 2poles 50Hz	5.5	132S	455	132	460	21	936	360	405	800	270	65	225	60	130	540	320	19	3.03
	7.5	132S	455	132	460	21	936	360	405	800	270	65	225	60	130	540	320	19	3.03
	11	160M	594	160	460	26	1080	450	420	1000	340	80	240	60	170	660	400	24	5.05
	15	160M	594	160	460	26	1080	450	420	1000	340	80	240	60	170	660	400	24	5.05

NM End Suction Centrifugal Pumps

Performance Curves 50 Hz

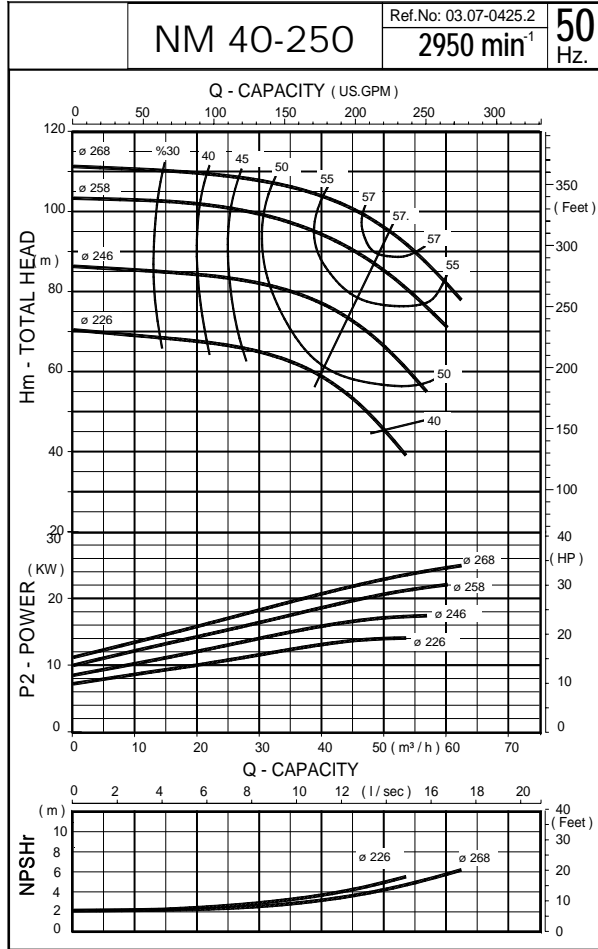
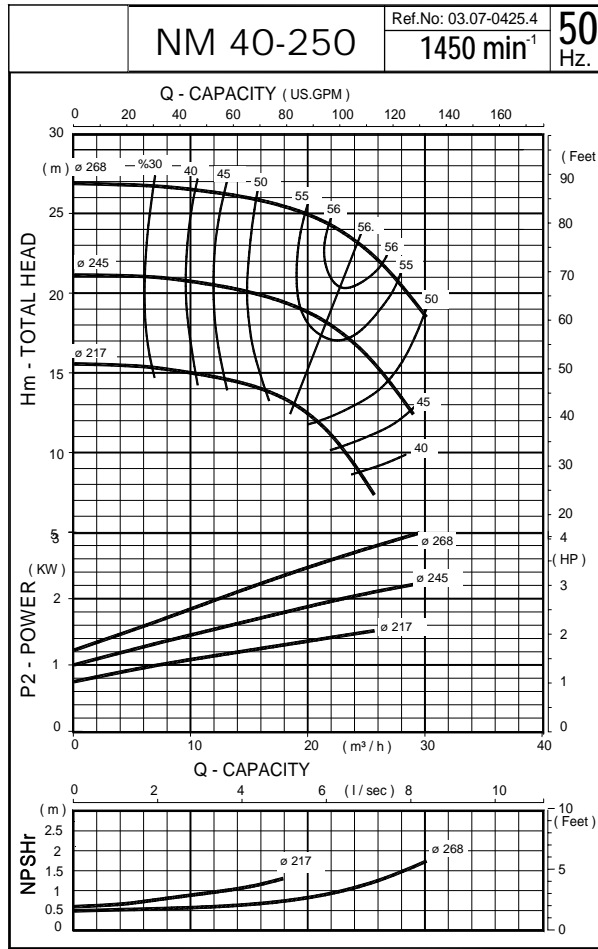

The Performance Curves 50 Hz are based on the kinematic viscosity 1 mm²/s and density 1g/cm³. Tolerances are acc. to ISO 9906 Annex A.

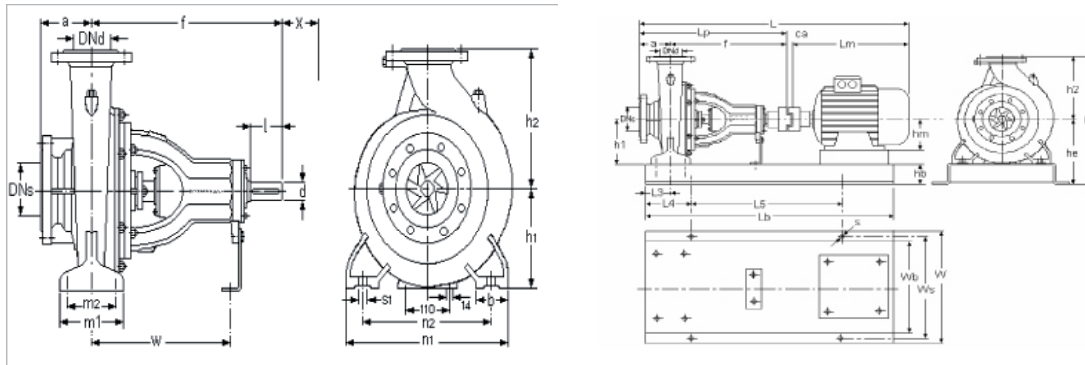

Pump size	Flanges		Length		Height		Mounting details							Shaft end		(*) X mm	Weight kg
	DNs mm	DNd mm	a mm	f mm	h1 mm	h2 mm	b mm	m1 mm	m2 mm	n1 mm	n2 mm	s1 mm	W mm	d mm	l mm		
40-250	65	40	100	360	180	225	65	125	95	320	250	M12	260	24	50	75	54

	MOTOR			PUMP		GENERAL				BASEPLATE									
	KW	IEC	Lm mm	Hm mm	Lp mm	Ca mm	L mm	W mm	H mm	Lb mm	Wb mm	Hb mm	He mm	L3 mm	L4 mm	L5 mm	Ws mm	S mm	Plate No
40-250 4pole 50Hz	1,5	90L	325	90	460	20	805	450	485	710	340	80	260	72	115	480	400	24	5,02
	2,2	100L	365	100	460	20	845	450	485	800	340	80	260	72	130	540	400	24	5,03
	3	100L	365	100	460	20	845	450	485	800	340	80	260	72	130	540	400	24	5,03
40-250 2pole 50Hz	11	160M	594	160	460	26	1080	450	485	1000	340	80	260	72	170	660	400	24	5,05
	15	160M	594	160	460	26	1080	450	485	1000	340	80	260	72	170	660	400	24	5,05
	18,5	160L	638	160	460	30	1128	450	485	1000	340	80	260	72	170	660	400	24	5,05
	22	180M	654	180	460	30	1144	490	485	1000	380	80	260	72	170	660	440	24	6,05
30	200L	747	200	460	30	1237	540	505	1120	430	80	280	72	190	740	490	24	7,06	

NM End Suction Centrifugal Pumps

Performance Curves 50 Hz

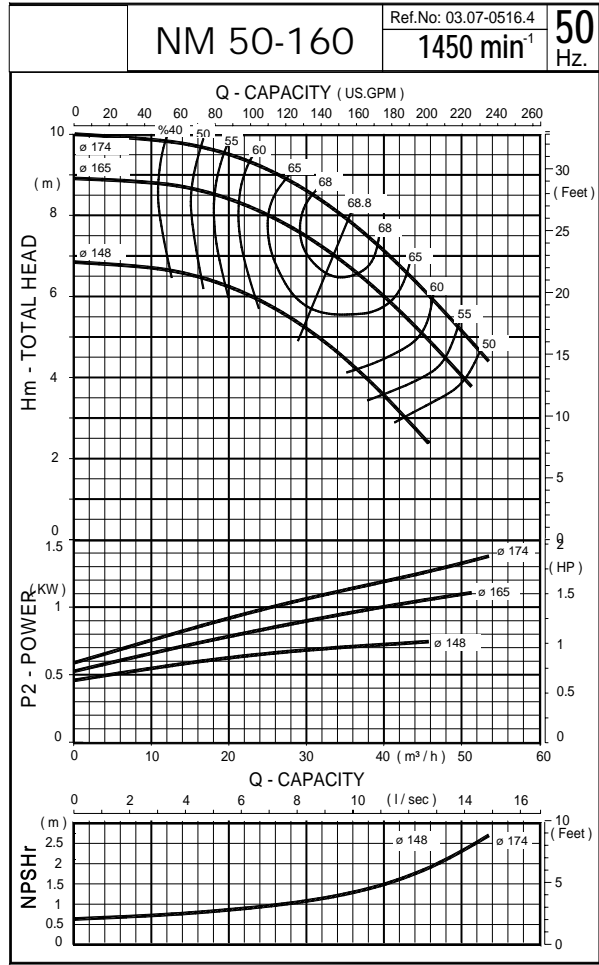
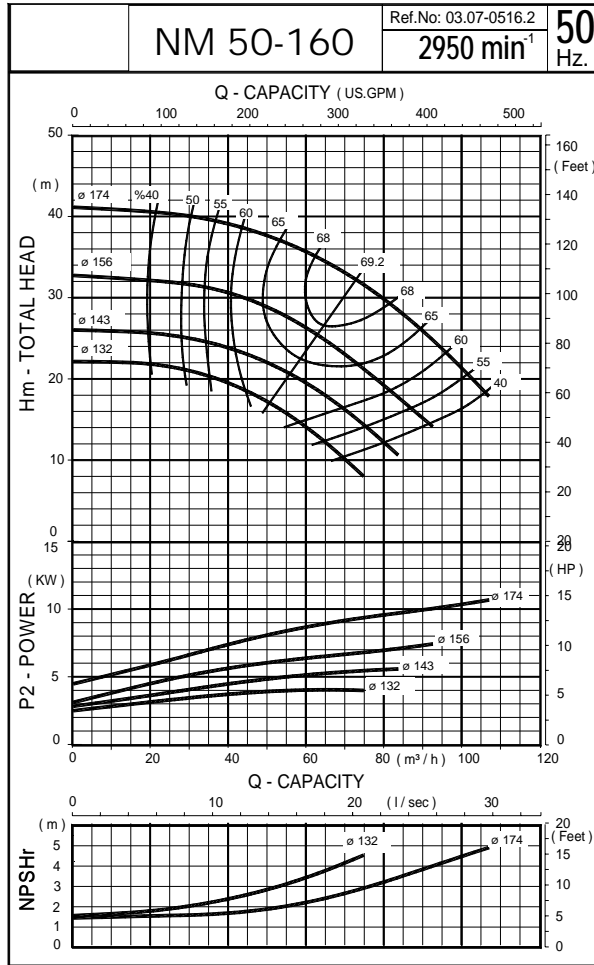

The Performance Curves 50 Hz are based on the kinematic viscosity 1 mm²/s and density 1g/cm³. Tolerances are acc. to ISO 9906 Annex A.

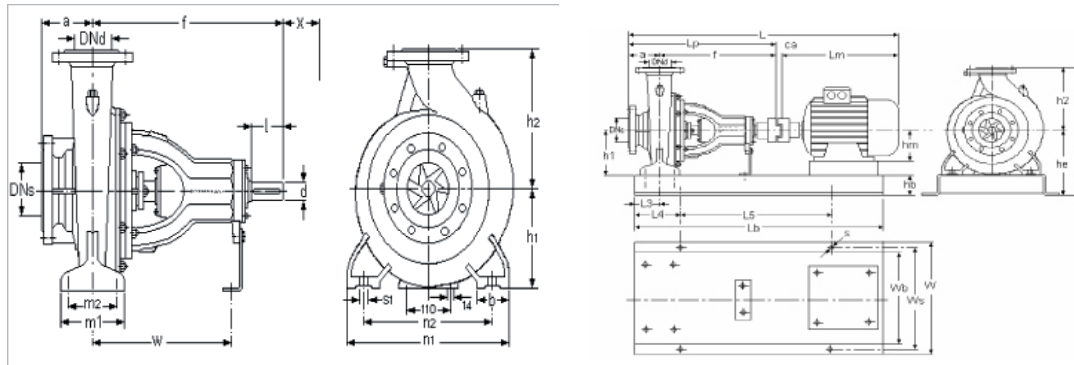

Pump size	Flanges		Length		Height		Mounting details						Shaft end		(*) X mm	Weight kg	
	DNs mm	DNd mm	a mm	f mm	h1 mm	h2 mm	b mm	m1 mm	m2 mm	n1 mm	n2 mm	s1 mm	W mm	d mm			l mm
50-160	65	50	100	360	160	180	50	100	70	265	212	M12	260	24	50	80	41.5

	MOTOR			PUMP		GENERAL				BASEPLATE									
	KW	IEC	Lm mm	Hm mm	Lp mm	Ca mm	L mm	W mm	H mm	Lb mm	Wb mm	Hb mm	He mm	L3 mm	L4 mm	L5 mm	Ws mm	S mm	Plate No
50-160 4poles 50Hz	0,75	80	273	80	460	16	749	360	405	710	270	65	225	60	115	480	320	19	3,02
	1,1	90S	300	90	460	20	780	360	405	710	270	65	225	60	115	480	320	19	3,02
	1,5	90L	325	90	460	20	805	360	405	710	270	65	225	60	115	480	320	19	3,02
50-160 2poles 50Hz	4	112M	384	112	460	20	864	360	405	800	270	65	225	60	130	540	320	19	3,03
	5,5	132S	455	132	460	21	936	360	405	800	270	65	225	60	130	540	320	19	3,03
	7,5	132S	455	132	460	21	936	360	405	800	270	65	225	60	130	540	320	19	3,03
	11	160M	594	160	460	26	1080	450	420	1000	340	80	240	60	170	660	400	24	5,05

NM End Suction Centrifugal Pumps

Performance Curves 50 Hz

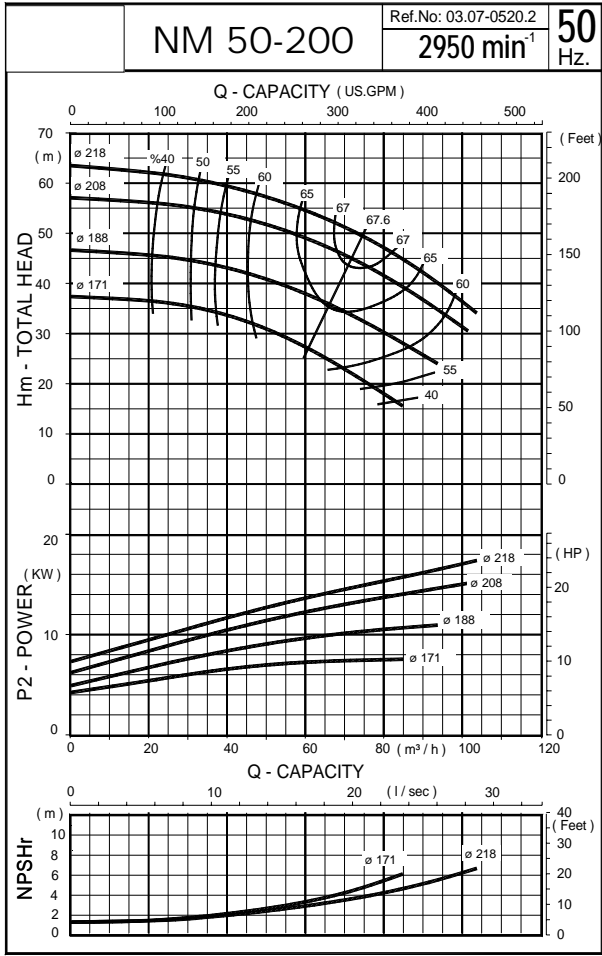
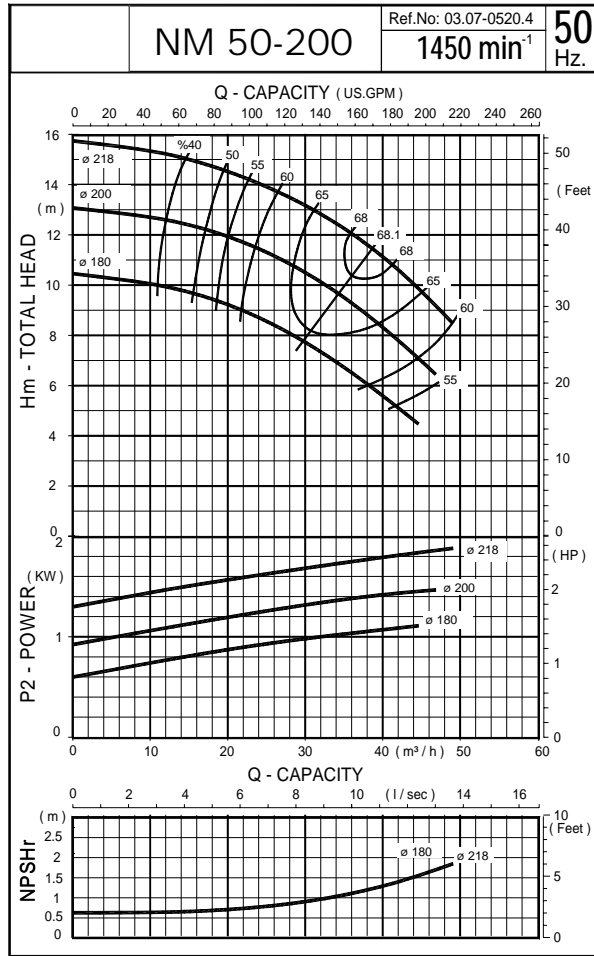

The Performance Curves 50 Hz are based on the kinematic viscosity 1 mm²/s and density 1g/cm³. Tolerances are acc. to ISO 9906 Annex A.

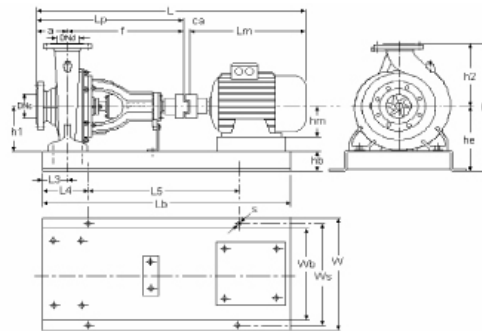
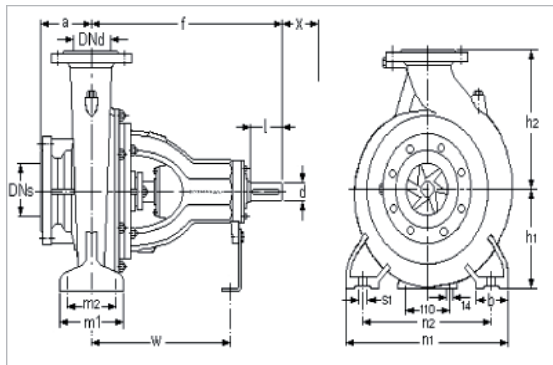

Pump size	Flanges		Length		Height		Mounting details						Shaft end		(*) X mm	Weight kg	
	DNs mm	DNd mm	a mm	f mm	h1 mm	h2 mm	b mm	m1 mm	m2 mm	n1 mm	n2 mm	s1 mm	W mm	d mm			l mm
50-200	65	50	100	360	160	200	50	100	70	265	212	M12	260	24	50	85	46.5

	MOTOR			PUMP			GENERAL				BASEPLATE								
	KW	IEC	Lm mm	Hm mm	Lp mm	Ca mm	L mm	W mm	H mm	Lb mm	Wb mm	Hb mm	He mm	L3 mm	L4 mm	L5 mm	Ws mm	S mm	Plate No
50-200 4poles 50Hz	1,1	90S	300	90	460	20	780	360	425	710	270	65	225	60	115	480	320	19	3,02
	1,5	90L	325	90	460	20	805	360	425	710	270	65	225	60	115	480	320	19	3,02
	2,2	100L	365	100	460	20	845	360	425	800	270	65	225	60	130	540	320	19	3,03
50-200 2poles 50Hz	7,5	132S	455	132	460	21	936	360	425	800	270	65	225	60	130	540	320	19	3,03
	11	160M	594	160	460	26	1080	450	440	1000	340	80	240	60	170	660	400	24	5,05
	15	160M	594	160	460	26	1080	450	440	1000	340	80	240	60	170	660	400	24	5,05
	18,5	160L	638	160	460	30	1128	450	440	1000	340	80	240	60	170	660	400	24	5,05

NM End Suction Centrifugal Pumps

Performance Curves 50 Hz

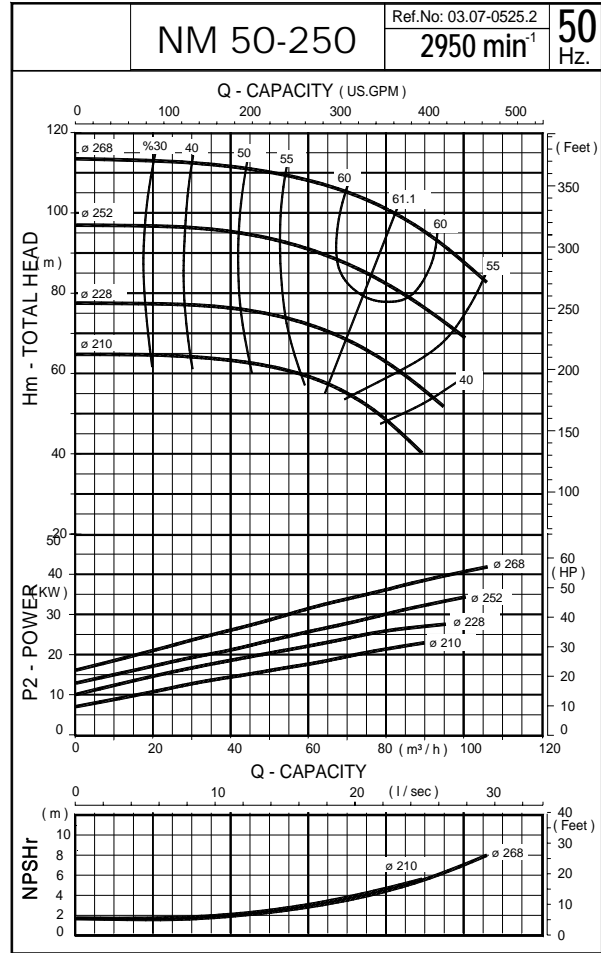
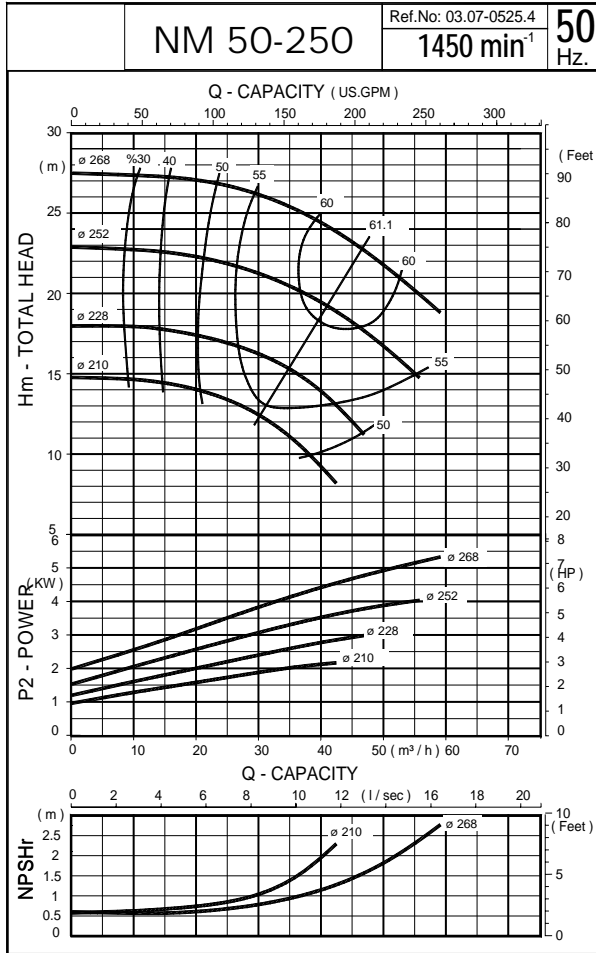

The Performance Curves 50 Hz are based on the kinematic viscosity 1 mm²/s and density 1g/cm³. Tolerances are acc. to ISO 9906 Annex A.

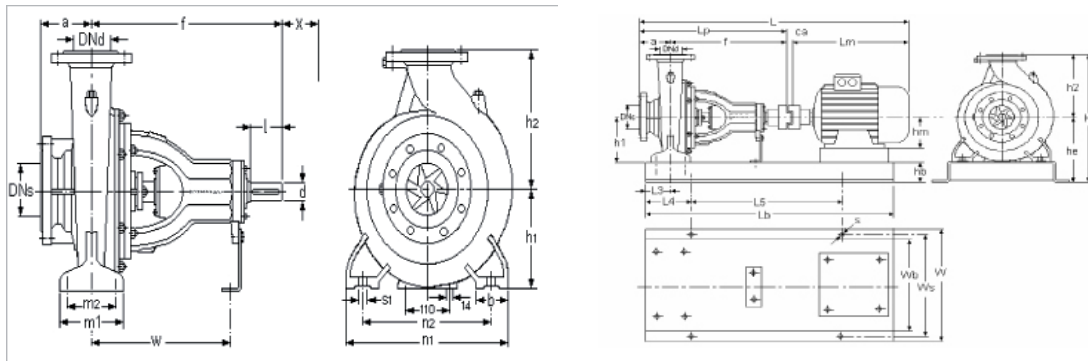

Pump size	Flanges		Length		Height		Mounting details						Shaft end		(*) X mm	Weight kg	
	DNs mm	DNd mm	a mm	f mm	h1 mm	h2 mm	b mm	m1 mm	m2 mm	n1 mm	n2 mm	s1 mm	W mm	d mm			l mm
50-250	65	50	100	360	180	225	65	125	95	320	250	M12	260	24	50	85	54.5

	MOTOR			PUMP			GENERAL			BASEPLATE									
	KW	IEC	Lm mm	Hm mm	Lp mm	Ca mm	L mm	W mm	H mm	Lb mm	Wb mm	Hb mm	He mm	L3 mm	L4 mm	L5 mm	Ws mm	S mm	Plate No
50-250	2,2	100L	365	100	460	20	845	450	485	800	340	80	260	72	130	540	400	24	5,03
50-250	3	100L	365	100	460	20	845	450	485	800	340	80	260	72	130	540	400	24	5,03
50-250	4	112M	384	112	460	21	865	450	485	800	340	80	260	72	130	540	400	24	5,03
50-250	5,5	132S	455	132	460	26	941	450	485	800	340	80	260	72	130	540	400	24	5,03
50-250	22	180M	654	180	460	30	1144	490	485	1000	380	80	260	72	170	660	440	24	6,05
50-250	30	200L	747	200	460	30	1237	540	505	1120	430	80	280	72	190	740	490	24	7,06
50-250	37	200L	747	200	460	33	1240	540	505	1120	430	80	280	72	190	740	490	24	7,06
50-250	45	225M	790	225	460	43	1293	610	550	1120	480	100	325	72	190	740	550	28	8,06

NM End Suction Centrifugal Pumps

Performance Curves 50 Hz

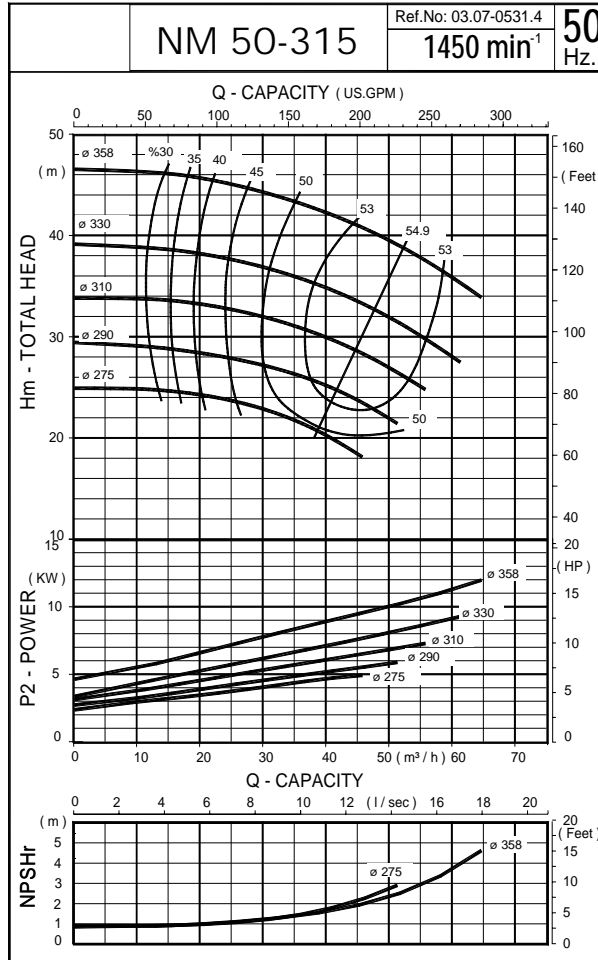

The Performance Curves 50 Hz are based on the kinematic viscosity 1 mm²/s and density 1g/cm³. Tolerances are acc. to ISO 9906 Annex A.

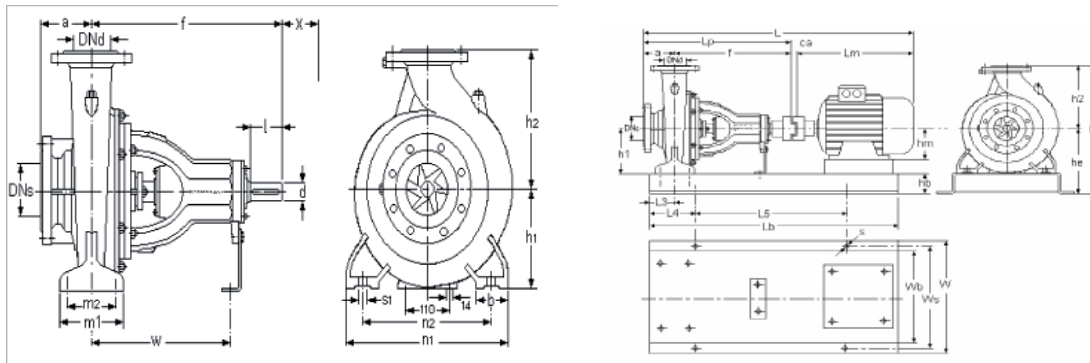

Pump size	Flanges		Length		Height		Mounting details							Shaft end		(*) X mm	Weight kg
	DNs mm	DNd mm	a mm	f mm	h1 mm	h2 mm	b mm	m1 mm	m2 mm	n1 mm	n2 mm	s1 mm	W mm	d mm	l mm		
50-315	80	50	100	470	225	280	80	160	120	360	280	M16	330	32	80	100	103

	MOTOR			PUMP		GENERAL				BASEPLATE									
	KW	IEC	Lm mm	Hm mm	Lp mm	Ca mm	L mm	W mm	H mm	Lb mm	Wb mm	Hb mm	He mm	L3 mm	L4 mm	L5 mm	Ws mm	S mm	Plate No
50-315 4poles 50Hz	4	112M	384	112	593	21	1000	490	585	900	380	80	305	72	150	600	440	24	6,04
	5,5	132S	455	132	595	26	1076	490	585	1000	380	80	305	72	170	660	440	24	6,05
	7,5	132M	493	132	595	26	1114	490	585	1000	380	80	305	72	170	660	440	24	6,05
	9	C132M	493	132	595	26	1114	490	585	1000	380	80	305	72	170	660	440	24	6,05
	11	160M	593	160	595	30	1219	490	585	1120	380	80	305	72	190	740	440	24	6,06

NM End Suction Centrifugal Pumps

Performance Curves 50 Hz

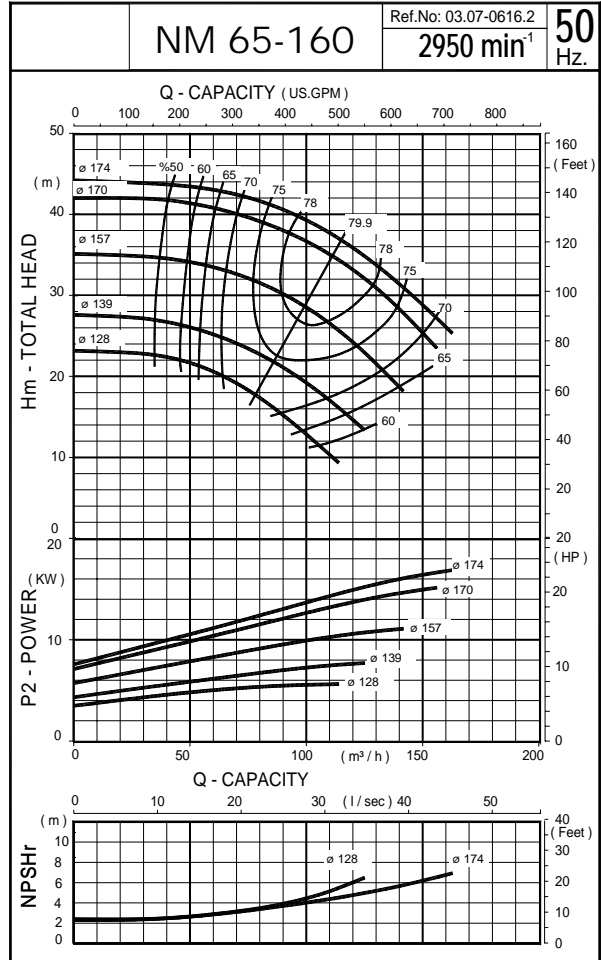
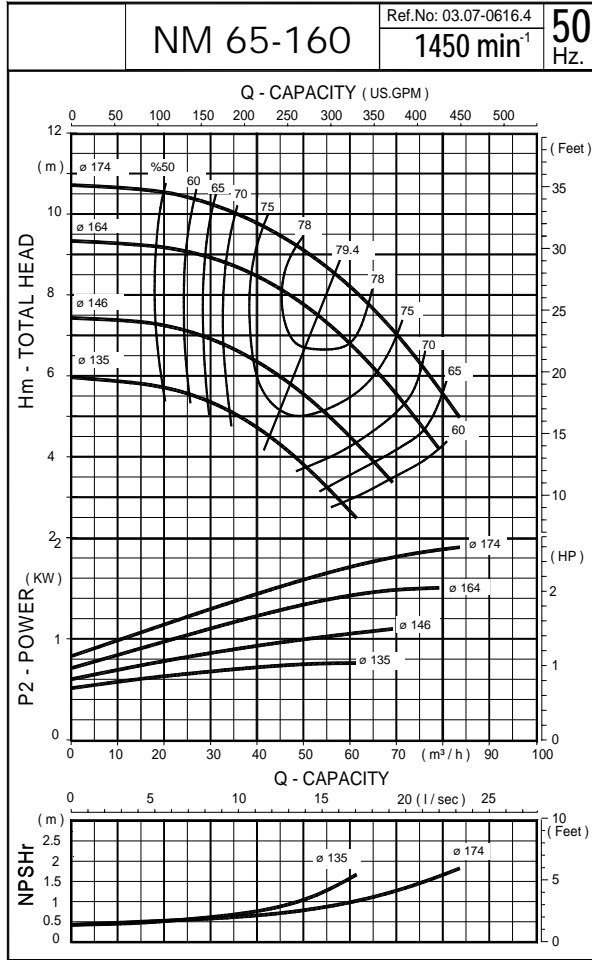

The Performance Curves 50 Hz are based on the kinematic viscosity 1 mm²/s and density 1g/cm³. Tolerances are acc. to ISO 9906 Annex A.

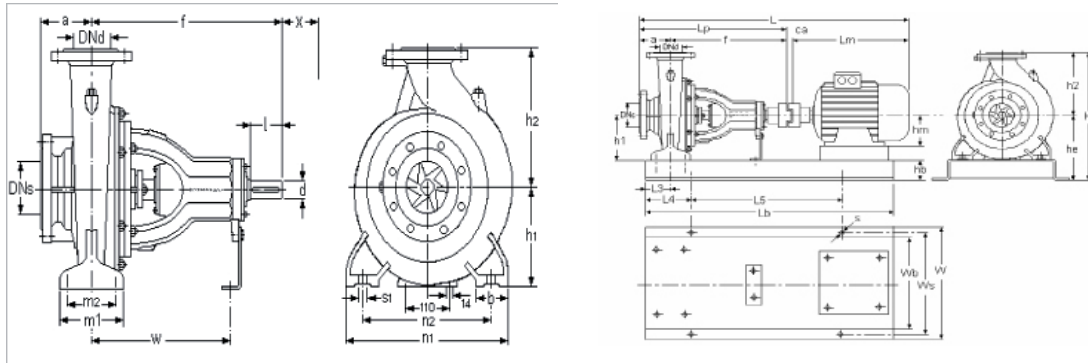

Pump size	Flanges		Length		Height		Mounting details						Shaft end		(*) X mm	Weight kg	
	DNs mm	DNd mm	a mm	f mm	h1 mm	h2 mm	b mm	m1 mm	m2 mm	n1 mm	n2 mm	s1 mm	W mm	d mm			l mm
65-160	80	65	100	360	160	200	65	125	95	280	212	M12	260	24	50	100	44

	MOTOR			PUMP			GENERAL			BASEPLATE									
	KW	IEC	Lm mm	Hm mm	Lp mm	Ca mm	L mm	W mm	H mm	Lb mm	Wb mm	Hb mm	He mm	L3 mm	L4 mm	L5 mm	Ws mm	S mm	Plate No
65-160 4 poles 50Hz	0,75	80	273	80	460	16	749	390	425	710	300	65	225	72	115	480	350	19	4,02
	1,1	90S	300	90	460	20	780	390	425	710	300	65	225	72	115	480	350	19	4,02
	1,5	90L	325	90	460	20	805	390	425	710	300	65	225	72	115	480	350	19	4,02
	2,2	100L	365	100	460	20	845	390	425	800	300	65	225	72	130	540	350	19	4,03
65-160 2 poles 50Hz	5,5	132S	455	132	460	21	936	390	425	800	300	65	225	72	130	540	350	19	4,03
	7,5	132S	455	132	460	21	936	390	425	800	300	65	225	72	130	540	350	19	4,03
	11	160M	594	160	460	26	1080	450	440	1000	340	80	240	72	170	660	400	24	5,05
	15	160M	594	160	460	26	1080	450	440	1000	340	80	240	72	170	660	400	24	5,05
	18,5	160L	638	160	460	30	1128	450	440	1000	340	80	240	72	170	660	400	24	5,05

NM End Suction Centrifugal Pumps

Performance Curves 50 Hz

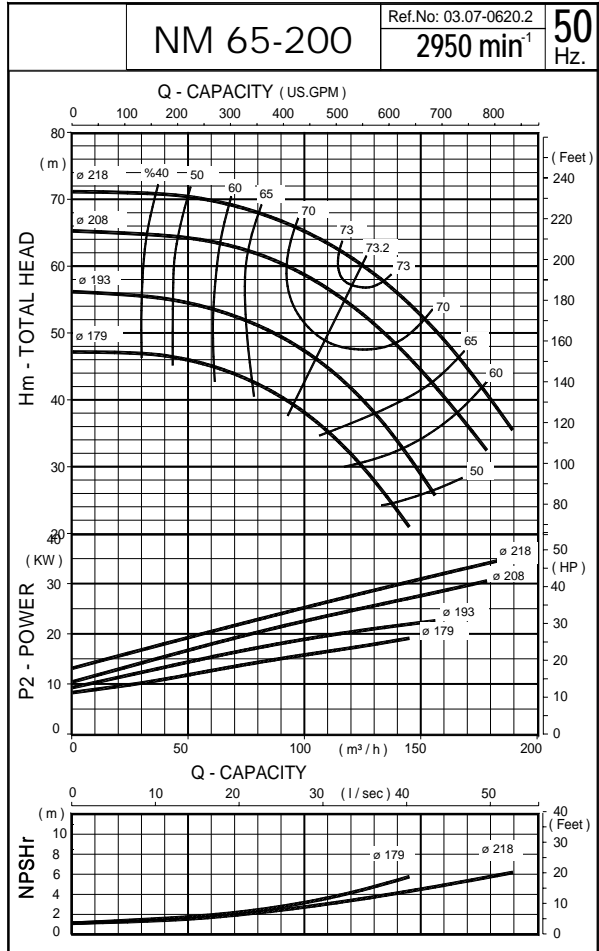
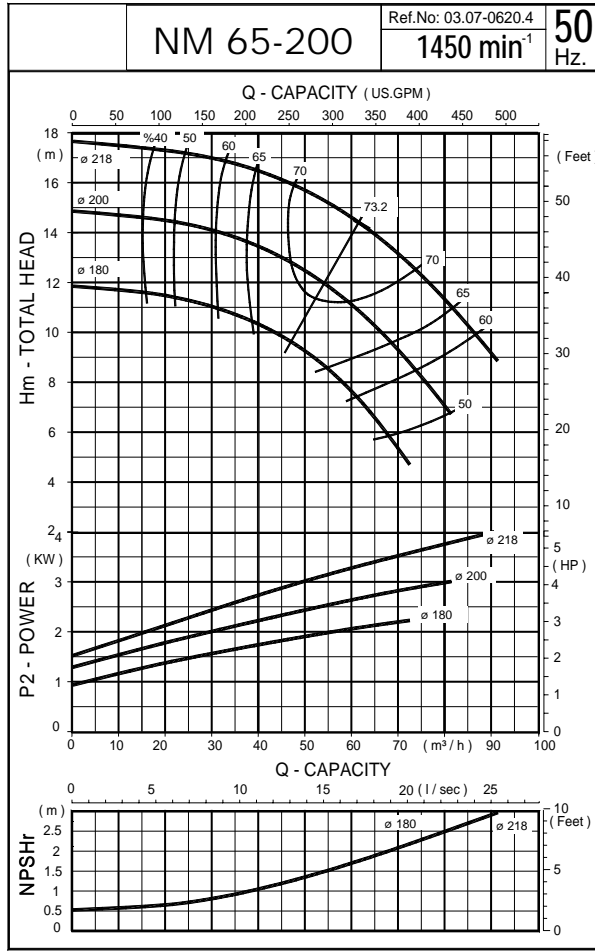

The Performance Curves 50 Hz are based on the kinematic viscosity 1 mm²/s and density 1g/cm³. Tolerances are acc. to ISO 9906 Annex A.

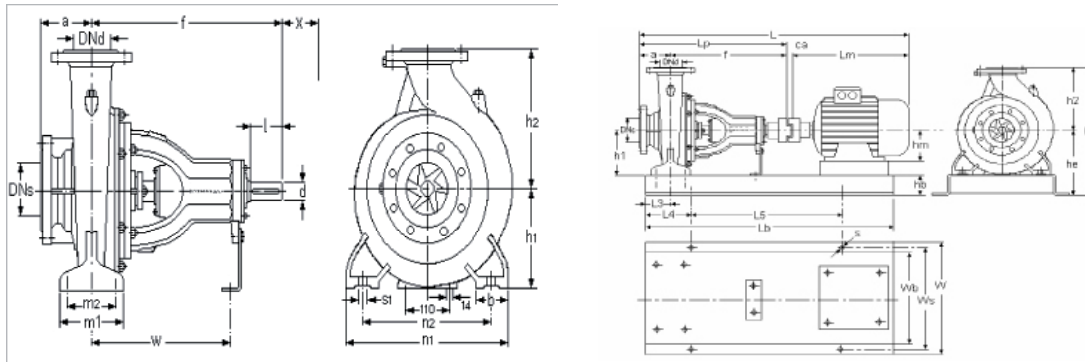

Pump size	Flanges		Length		Height		Mounting details						Shaft end		(*) X mm	Weight kg	
	DNs mm	DNd mm	a mm	f mm	h1 mm	h2 mm	b mm	m1 mm	m2 mm	n1 mm	n2 mm	s1 mm	W mm	d mm			l mm
65-200	80	65	100	360	180	225	65	125	95	320	250	M12	260	24	50	100	47.5

	MOTOR			PUMP			GENERAL				BASEPLATE								
	KW	IEC	Lm mm	Hm mm	Lp mm	Ca mm	L mm	W mm	H mm	Lb mm	Wb mm	Hb mm	He mm	L3 mm	L4 mm	L5 mm	Ws mm	S mm	Plate No
65-200 4 poles 50Hz	2,2	100L	365	100	460	20	845	450	485	800	340	80	260	72	130	540	400	24	5,03
	3	100L	365	100	460	20	845	450	485	800	340	80	260	72	130	540	400	24	5,03
	4	112M	384	112	460	21	865	450	485	800	340	80	260	72	130	540	400	24	5,03
65-200 2 poles 50Hz	18,5	160L	638	160	460	30	1128	450	485	1000	340	80	260	72	170	660	400	24	5,05
	22	180M	654	180	460	30	1144	490	485	1000	380	80	260	72	170	660	440	24	6,05
	30	200L	747	200	460	30	1237	540	505	1120	430	80	280	72	190	740	490	24	7,06
	37	200L	747	200	460	33	1240	540	505	1120	430	80	280	72	190	740	490	24	7,06

NM End Suction Centrifugal Pumps

Performance Curves 50 Hz

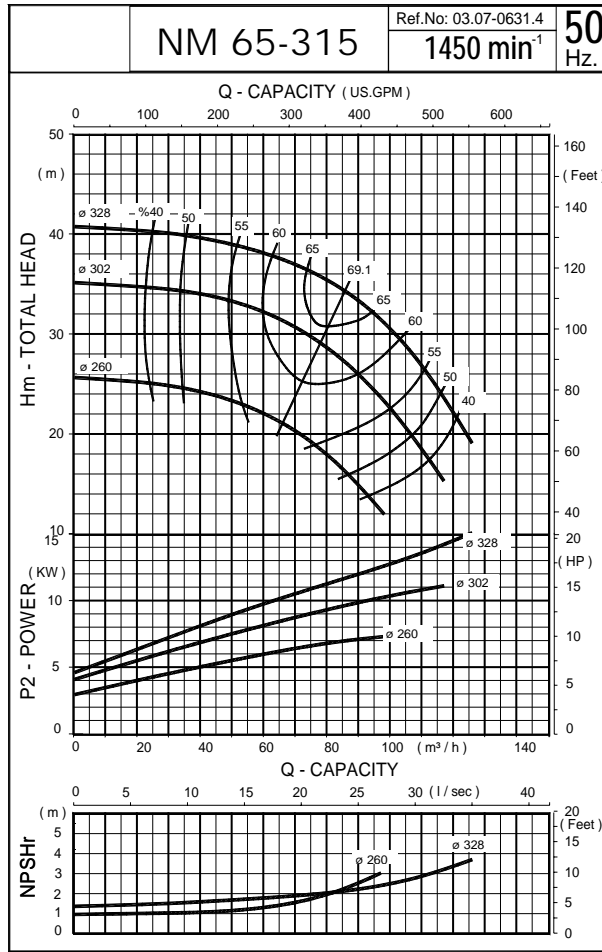

The Performance Curves 50 Hz are based on the kinematic viscosity 1 mm²/s and density 1g/cm³. Tolerances are acc. to ISO 9906 Annex A.

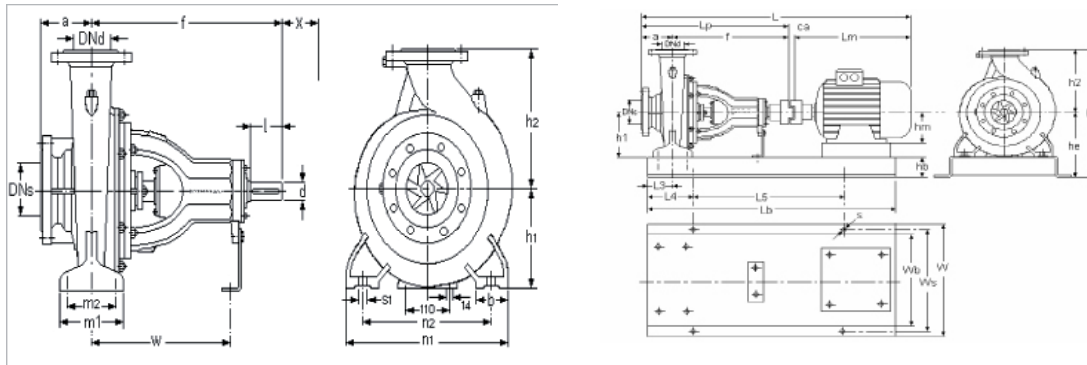

Pump size	Flanges		Length		Height		Mounting details							Shaft end		(*) X mm	Weight kg
	DNs mm	DNd mm	a mm	f mm	h1 mm	h2 mm	b mm	m1 mm	m2 mm	n1 mm	n2 mm	s1 mm	W mm	d mm	l mm		
65-315	80	65	125	470	225	280	80	160	120	400	315	M16	340	32	80	110	92

	MOTOR			PUMP		GENERAL				BASEPLATE									
	KW	IEC	Lm mm	Hm mm	Lp mm	Ca mm	L mm	W mm	H mm	Lb mm	Wb mm	Hb mm	He mm	L3 mm	L4 mm	L5 mm	Ws mm	S mm	Plate No
65-315 4 poles 50Hz	7,5	132M	493	132	595	26	1114	540	585	1000	430	80	305	90	170	660	490	24	7,05
	9	C132M	493	132	595	26	1114	540	585	1000	430	80	305	90	170	660	490	24	7,05
	11	160M	594	160	595	30	1219	540	585	1120	430	80	305	90	190	740	490	24	7,06
	15	160L	630	160	595	30	1263	540	585	1120	430	80	305	90	190	740	490	24	7,06

NM End Suction Centrifugal Pumps

Performance Curves 50 Hz

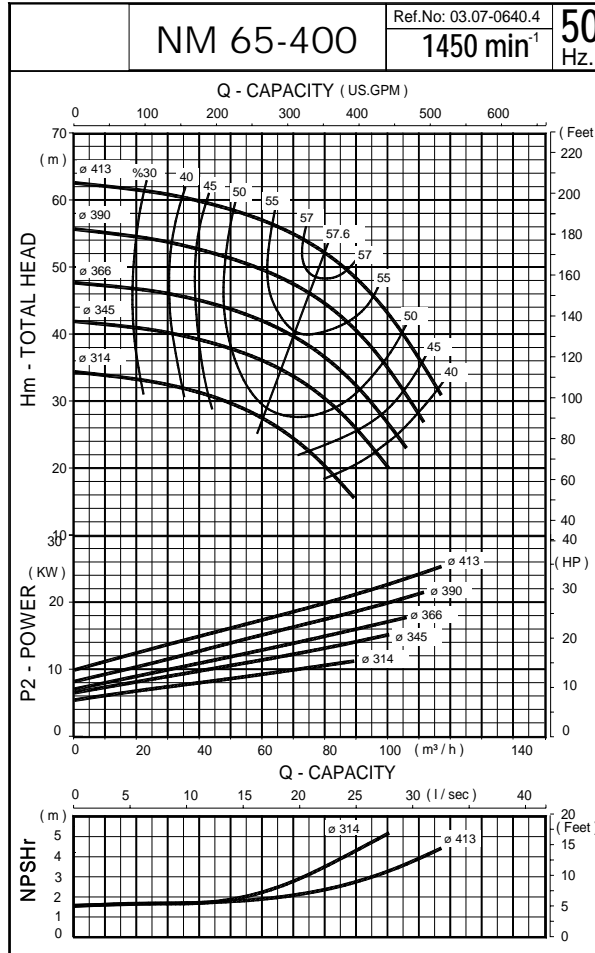

The Performance Curves 50 Hz are based on the kinematic viscosity 1 mm²/s and density 1g/cm³. Tolerances are acc. to ISO 9906 Annex A.

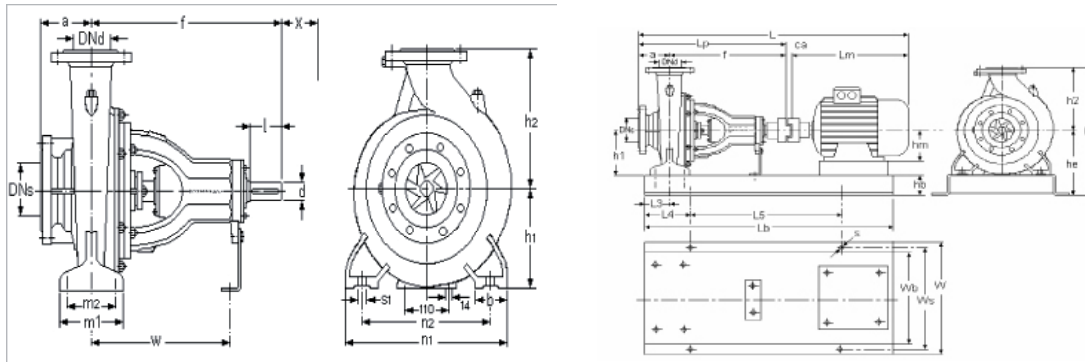

Pump size	Flanges		Length		Height		Mounting details						Shaft end		(*) X mm	Weight kg	
	DNs mm	DNd mm	a mm	f mm	h1 mm	h2 mm	b mm	m1 mm	m2 mm	n1 mm	n2 mm	s1 mm	W mm	d mm			l mm
65-400	100	65	125	470	250	355	80	160	120	400	315	M16	340	32	80	110	125

	MOTOR			PUMP		GENERAL				BASEPLATE									
	KW	IEC	Lm mm	Hm mm	Lp mm	Ca mm	L mm	W mm	H mm	Lb mm	Wb mm	Hb mm	He mm	L3 mm	L4 mm	L5 mm	Ws mm	S mm	Plate No
65-400 4 poles 50Hz	11	160M	594	160	595	30	1219	540	685	1120	430	80	330	90	190	740	490	24	7,06
	15	160L	638	160	595	30	1263	540	685	1120	430	80	330	90	190	740	490	24	7,06
	18,5	180M	654	180	595	33	1282	540	685	1120	430	80	330	90	190	740	490	24	7,06
	22	180L	692	180	595	33	1320	540	685	1250	430	80	330	90	205	840	490	24	7,07
	30	200L	747	200	595	42	1384	540	685	1250	430	80	330	90	205	840	490	24	7,07

NM End Suction Centrifugal Pumps

Performance Curves 50 Hz

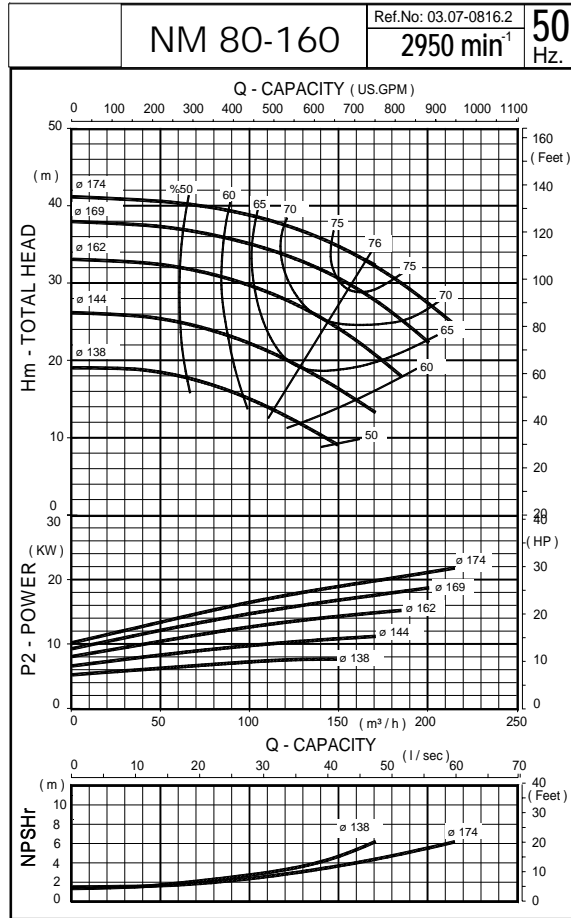
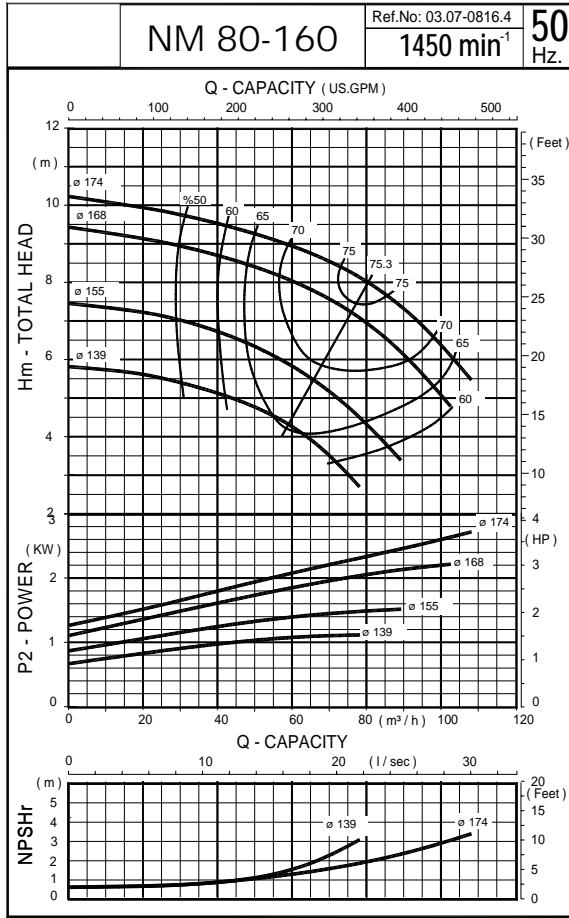

The Performance Curves 50 Hz are based on the kinematic viscosity 1 mm²/s and density 1g/cm³. Tolerances are acc. to ISO 9906 Annex A.

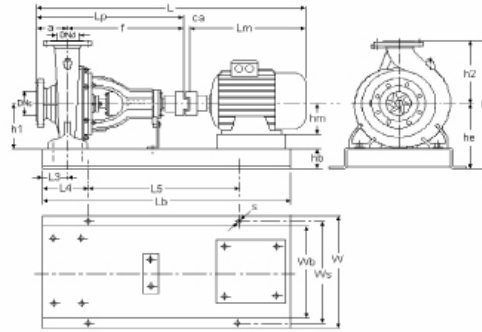
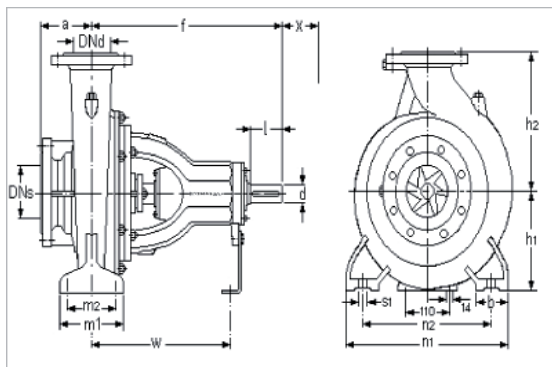

Pump size	Flanges		Length		Height		Mounting details						Shaft end		(*) X mm	Weight kg	
	DNs mm	DNd mm	a mm	f mm	h1 mm	h2 mm	b mm	m1 mm	m2 mm	n1 mm	n2 mm	s1 mm	W mm	d mm			l mm
80-160	100	80	125	360	180	225	65	125	95	320	250	M12	260	24	50	110	51

	MOTOR			PUMP		GENERAL				BASEPLATE									
	KW	IEC	Lm mm	Hm mm	Lp mm	Ca mm	L mm	W mm	H mm	Lb mm	Wb mm	Hb mm	He mm	L3 mm	L4 mm	L5 mm	Ws mm	S mm	Plate No
80-160	1,1	90S	300	90	485	20	805	450	485	710	340	80	260	72	115	480	400	24	5,02
80-160	1,5	90L	325	90	485	20	830	450	485	710	340	80	260	72	115	480	400	24	5,02
80-160	2,2	100L	365	100	485	20	870	450	485	800	340	80	260	72	130	540	400	24	5,03
80-160	3	100L	365	100	485	20	870	450	485	800	340	80	260	72	130	540	400	24	5,03
80-160	7,5	132S	455	132	485	21	961	450	485	800	340	80	260	72	130	540	400	24	5,03
80-160	11	160M	594	160	485	26	1105	450	485	1000	340	80	260	72	170	660	400	24	5,05
80-160	15	160M	594	160	485	26	1105	450	485	1000	340	80	260	72	170	660	400	24	5,05
80-160	18,5	160L	638	160	485	30	1153	450	485	1000	340	80	260	72	170	660	400	24	5,05
80-160	22	180M	654	180	485	30	1169	490	485	1000	380	80	260	72	170	660	440	24	6,05

NM End Suction Centrifugal Pumps

Performance Curves 50 Hz

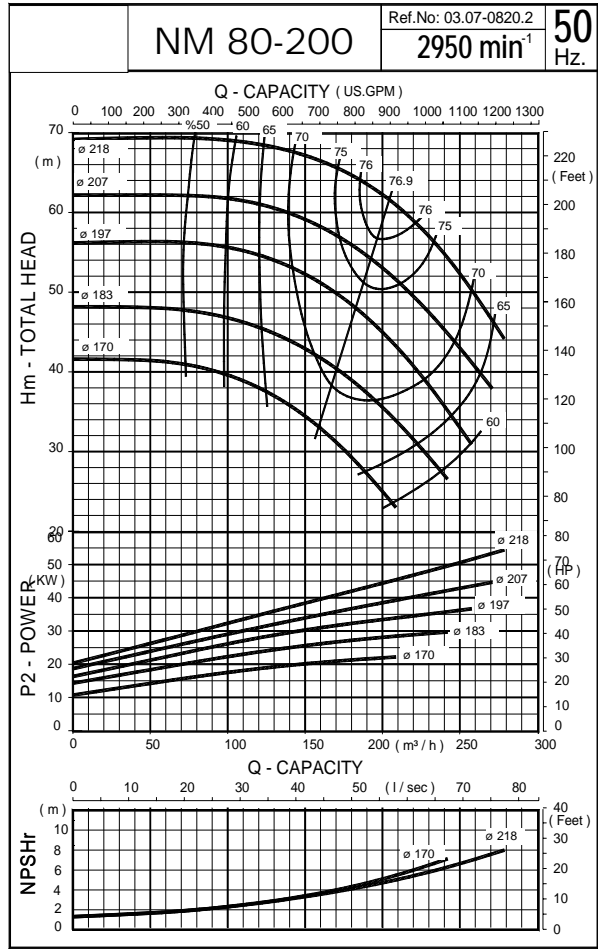
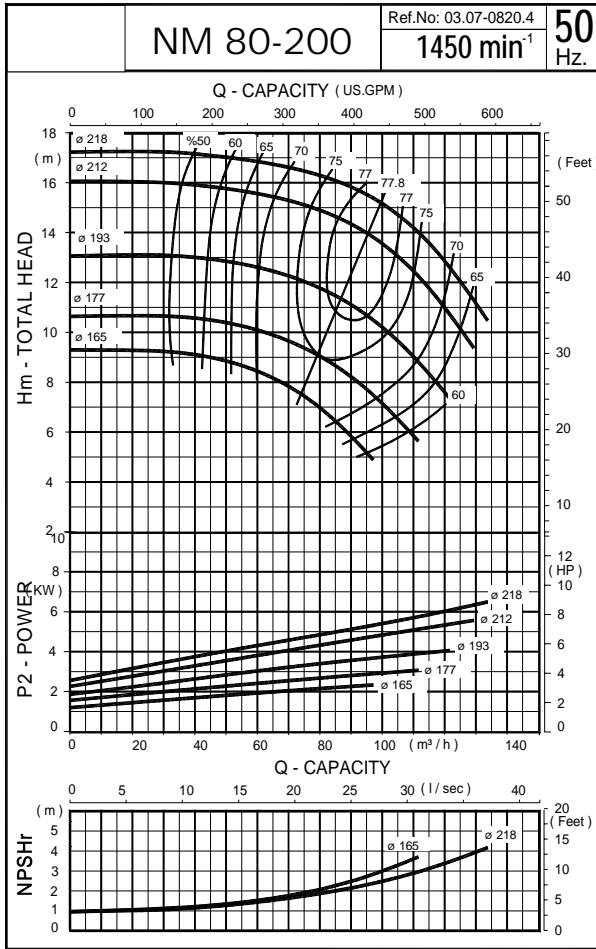

The Performance Curves 50 Hz are based on the kinematic viscosity 1 mm²/s and density 1g/cm³. Tolerances are acc. to ISO 9906 Annex A.

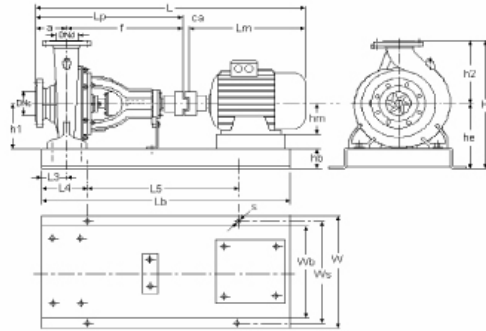
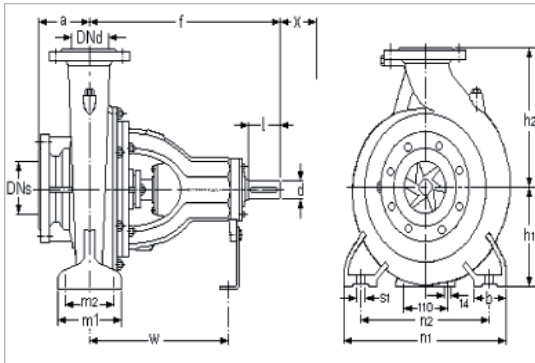

Pump size	Flanges		Length		Height		Mounting details							Shaft end		(*) X mm	Weight kg
	DNs mm	DNd mm	a mm	f mm	h1 mm	h2 mm	b mm	m1 mm	m2 mm	n1 mm	n2 mm	s1 mm	W mm	d mm	l mm		
80-200	100	80	125	470	180	250	65	125	95	345	280	M12	340	32	80	110	75.5

	MOTOR		PUMP		GENERAL			BASEPLATE											
	KW	IEC	Lm mm	Hm mm	Lp mm	Ca mm	L mm	W mm	H mm	Lb mm	Wb mm	Hb mm	He mm	L3 mm	L4 mm	L5 mm	Ws mm	S mm	Plate No
80-200 4 poles 50 Hz	3	100L	365	100	595	20	980	490	510	900	380	80	260	72	150	600	440	24	6,04
	4	112M	384	112	595	21	1000	490	510	900	380	80	260	72	150	600	440	24	6,04
	5,5	132S	455	132	595	26	1076	490	510	1000	380	80	260	72	170	660	440	24	6,05
	7,5	132M	493	132	595	26	1114	490	510	1000	380	80	260	72	170	660	440	24	6,05
80-200 4 poles 50 Hz	30	200L	747	200	595	30	1372	540	530	1250	430	80	280	72	205	840	490	24	7,07
	37	200L	747	200	595	33	1375	540	530	1250	430	80	280	72	205	840	490	24	7,07
	45	225M	790	225	595	43	1428	60	575	1250	480	100	325	72	205	840	550	28	8,07
	55	250M	890	250	595	42	1527	540	580	1400	430	80	330	72	230	940	490	24	7,08

NM End Suction Centrifugal Pumps

Performance Curves 50 Hz

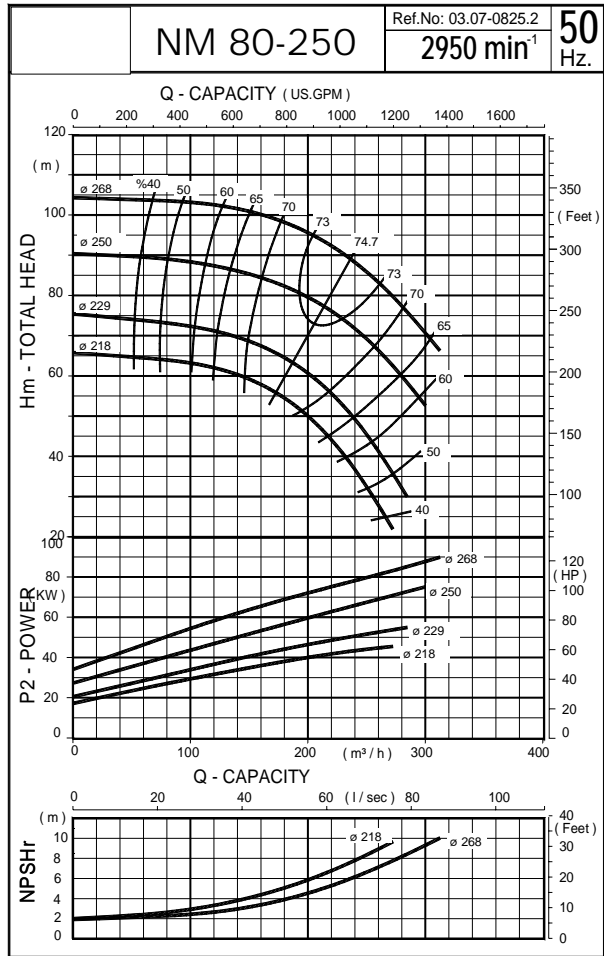
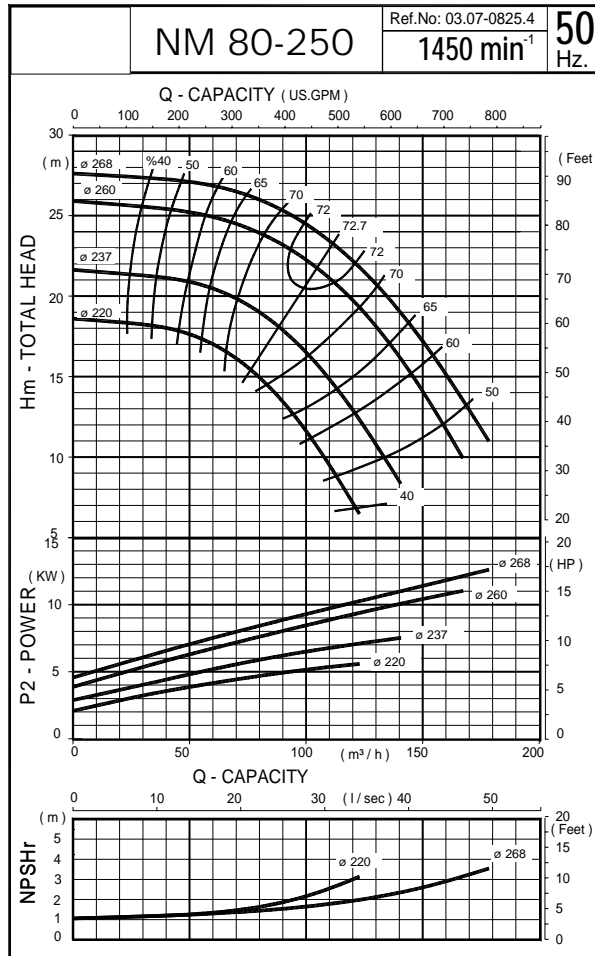

The Performance Curves 50 Hz are based on the kinematic viscosity 1 mm²/s and density 1g/cm³. Tolerances are acc. to ISO 9906 Annex A.

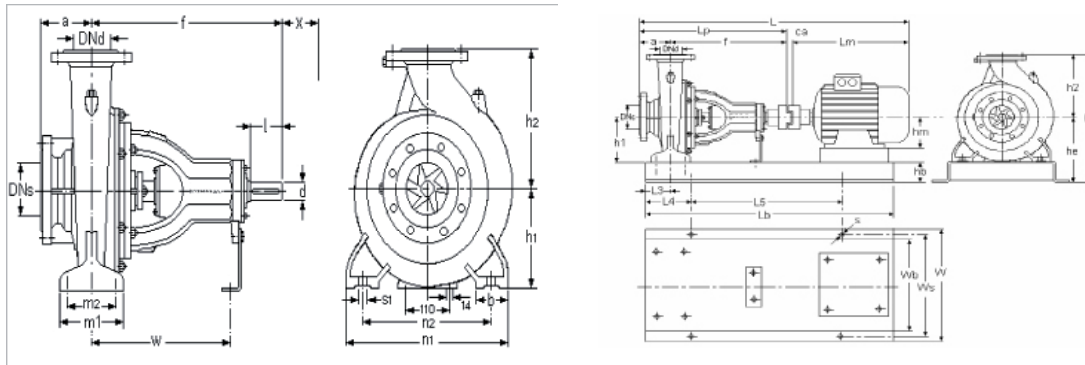

Pump size	Flanges		Length		Height		Mounting details						Shaft end		(*) X mm	Weight kg	
	DNs mm	DNd mm	a mm	f mm	h1 mm	h2 mm	b mm	m1 mm	m2 mm	n1 mm	n2 mm	s1 mm	W mm	d mm			l mm
80-250	100	80	125	470	200	280	80	160	120	400	315	M16	340	32	80	115	93

	MOTOR			PUMP			GENERAL				BASEPLATE								
	KW	IEC	Lm mm	Hm mm	Lp mm	Ga mm	L mm	W mm	H mm	Lb mm	Wb mm	Hb mm	He mm	L3 mm	L4 mm	L5 mm	Ws mm	S mm	Plate No
80-250 4 poles 50Hz	5,5	132S	455	132	595	26	1076	540	560	1000	430	80	280	90	170	660	490	24	7,05
	7,5	132M	493	132	595	26	1114	540	560	1000	430	80	280	90	170	660	490	24	7,05
	9	C132M	493	132	595	26	1114	540	560	1000	430	80	280	90	170	660	490	24	7,05
	11	160M	594	160	595	30	1219	540	560	1120	430	80	280	90	190	740	490	24	7,06
80-250 2 poles 50Hz	45	225M	1190	225	595	43	1428	610	605	1250	480	100	325	90	205	840	550	28	8,07
	55	250M	890	250	595	42	1527	540	610	1400	430	80	330	90	230	940	490	24	7,08
	75	280S	958	280	595	43	1596	730	660	1400	600	100	380	90	230	940	670	28	10,08
	90	280M	1010	280	595	43	1648	730	660	1600	600	100	380	90	270	1060	670	28	10,09

NM End Suction Centrifugal Pumps

Performance Curves 50 Hz

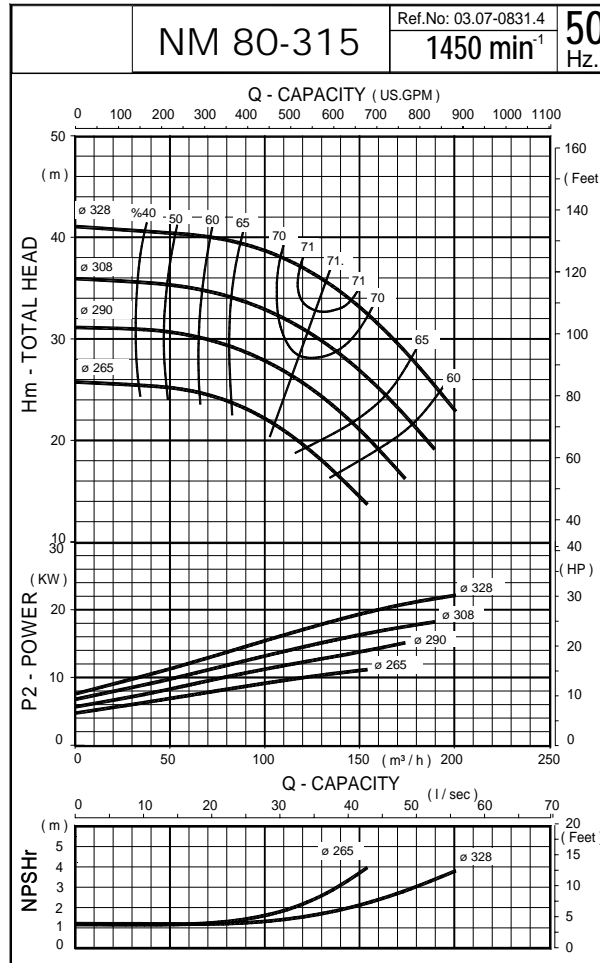

The Performance Curves 50 Hz are based on the kinematic viscosity 1 mm²/s and density 1g/cm³. Tolerances are acc. to ISO 9906 Annex A.

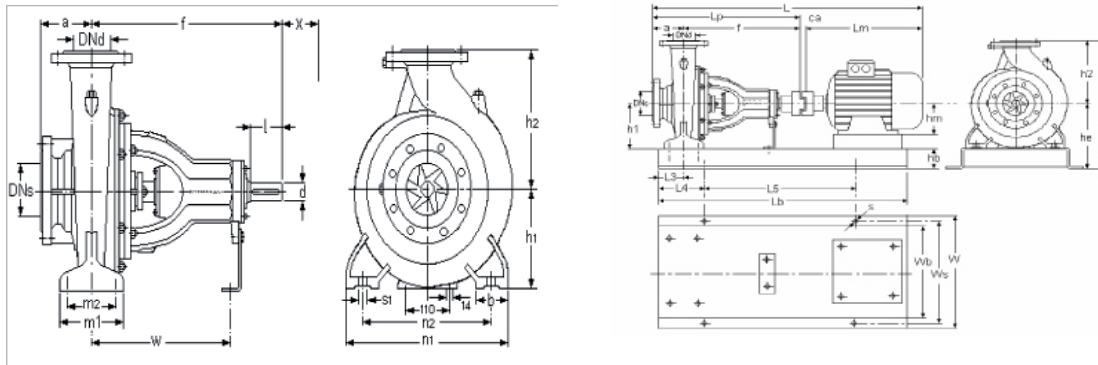

Pump size	Flanges		Length		Height		Mounting details							Shaft end		(*) X mm	Weight kg
	DNs mm	DNd mm	a mm	f mm	h1 mm	h2 mm	b mm	m1 mm	m2 mm	n1 mm	n2 mm	s1 mm	W mm	d mm	l mm		
80-315	100	80	125	470	250	315	80	160	120	400	315	M16	340	32	80	120	107

	MOTOR			PUMP		GENERAL			BASEPLATE										
	KW	IEC	Lm mm	Hm mm	Lp mm	Ca mm	L mm	W mm	H mm	Lb mm	Wb mm	Hb mm	He mm	L3 mm	L4 mm	L5 mm	Ws mm	S mm	Plate No
80-315 4 poles 50 Hz	11	160M	594	160	595	30	1219	540	645	1120	430	80	330	90	190	740	490	24	7.06
	15	160L	638	160	595	30	1263	540	645	1120	430	80	330	90	190	740	490	24	7.06
	18,5	180M	654	180	595	33	1282	540	645	1120	430	80	330	90	190	740	490	24	7.06
	22	180L	692	180	595	33	1320	540	645	1250	430	80	330	90	205	840	490	24	7.07

NM End Suction Centrifugal Pumps

Performance Curves 50 Hz

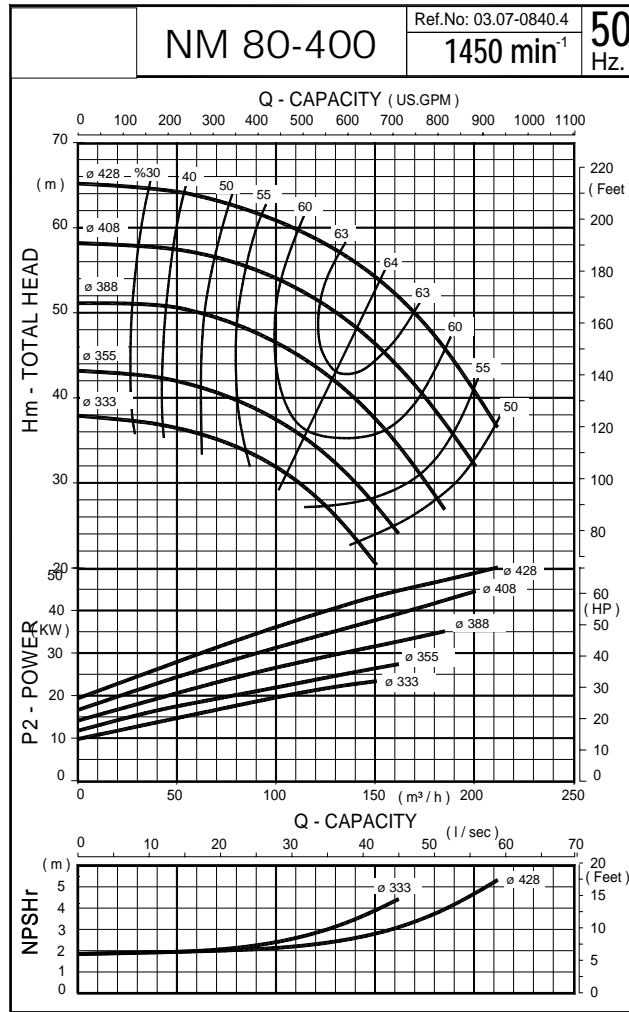

The Performance Curves 50 Hz are based on the kinematic viscosity 1 mm²/s and density 1g/cm³. Tolerances are acc. to ISO 9906 Annex A.

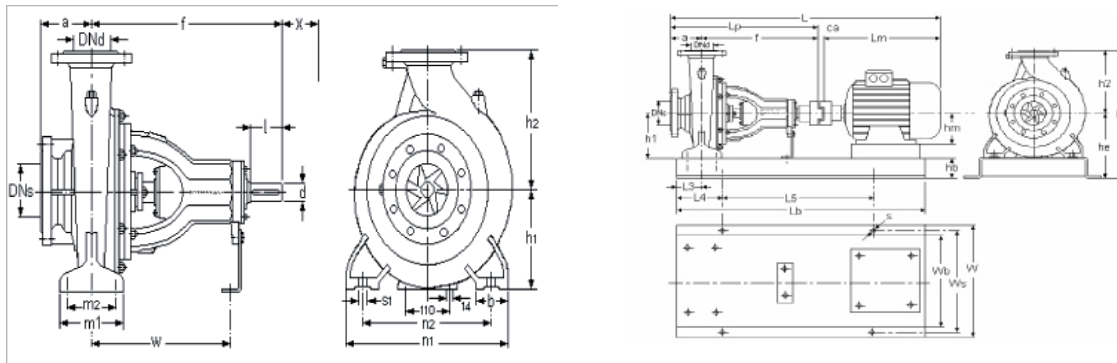

Pump size	Flanges		Length		Height		Mounting details							Shaft end		(*) X mm	Weight kg
	DNs mm	DNd mm	a mm	f mm	h1 mm	h2 mm	b mm	m1 mm	m2 mm	n1 mm	n2 mm	s1 mm	W mm	d mm	l mm		
80-400	100	80	125	530	280	355	100	200	150	500	400	M20	370	42	110	120	162

	MOTOR			PUMP		GENERAL					BASEPLATE									
	KW	IEC	Lm mm	Hm mm	Lp mm	Ca mm	L mm	W mm	H mm	Lb mm	Wb mm	Hb mm	He mm	L3 mm	L4 mm	L5 mm	Ws mm	S mm	Plate No	
80-400	18,5	180M	654	180	655	33	1342	660	735	1250	530	100	380	110	205	840	600	28	9,07	
80-400	22	180L	692	180	655	33	1380	660	735	1250	530	100	380	110	205	840	600	28	9,07	
80-400	30	200L	747	200	655	42	1444	660	735	1400	530	100	380	110	230	940	600	28	9,08	
80-400	37	225S	795	225	655	43	1493	660	735	1400	530	100	380	110	230	940	600	28	9,08	
80-400	45	225M	820	225	655	43	1518	660	735	1400	530	100	380	110	230	940	600	28	9,08	

NM End Suction Centrifugal Pumps

Performance Curves 50 Hz

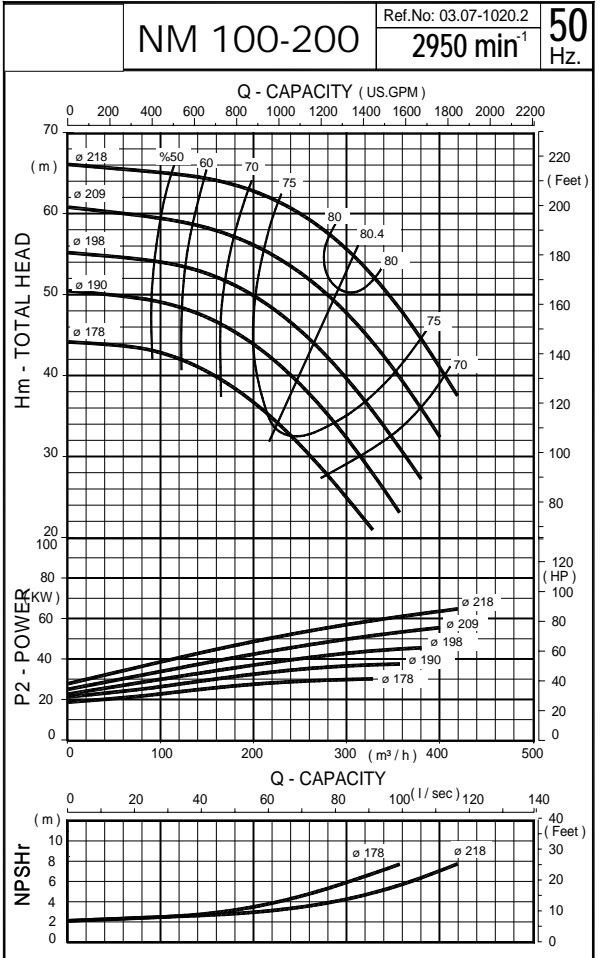
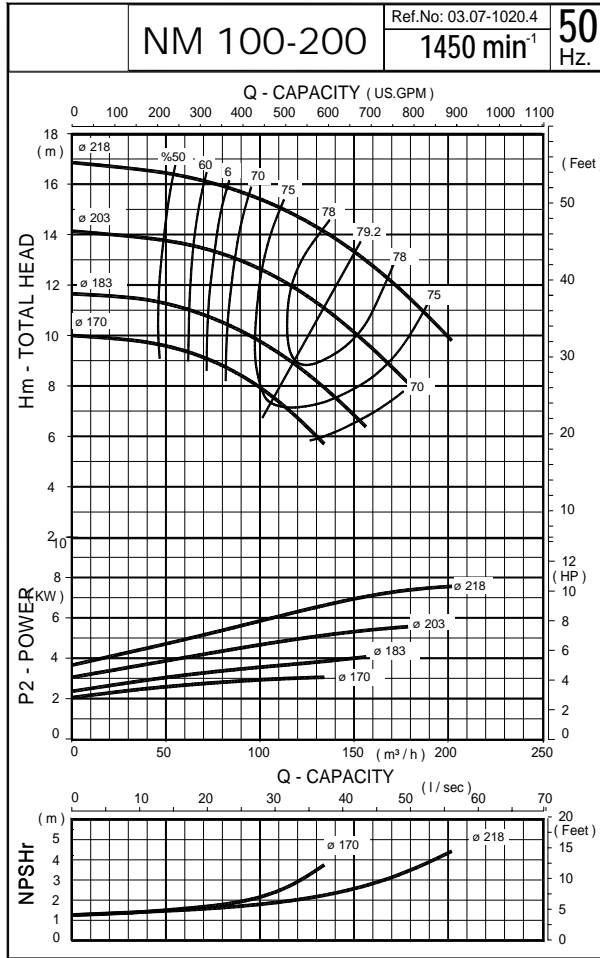

The Performance Curves 50 Hz are based on the kinematic viscosity 1 mm²/s and density 1g/cm³. Tolerances are acc. to ISO 9906 Annex A.

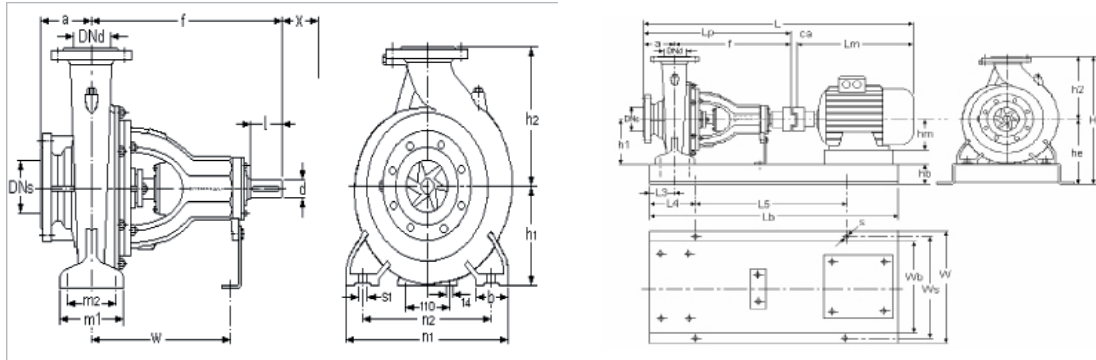

Pump size	Flanges		Length		Height		Mounting details							Shaft end		(*) X mm	Weight kg
	DNs mm	DNd mm	a mm	f mm	h1 mm	h2 mm	b mm	m1 mm	m2 mm	n1 mm	n2 mm	s1 mm	W mm	d mm	l mm		
100-200	125	100	125	470	200	280	80	160	120	360	280	M16	340	32	80	120	83

	MOTOR			PUMP			GENERAL				BASEPLATE								
	KW	IEC	Lm mm	Hm mm	Lp mm	Ca mm	L mm	W mm	H mm	Lb mm	Wb mm	Hb mm	He mm	L3 mm	L4 mm	L5 mm	Ws mm	S mm	Plate No
100-200 4 poles 50Hz	3	100L	365	100	595	20	980	490	560	900	380	80	280	90	150	600	440	24	6,04
	4	112M	384	112	595	21	1000	490	560	900	380	80	280	90	150	600	440	24	6,04
	5,5	132S	455	132	595	26	1076	490	560	1000	380	80	280	90	170	660	440	24	6,05
	7,5	132M	493	132	595	26	1114	490	560	1000	380	80	280	90	170	660	440	24	6,05
100-200 2 poles 50Hz	30	200L	747	200	595	30	1372	540	560	1250	430	80	280	90	205	840	490	24	7,07
	37	200L	747	200	595	33	1375	540	560	1250	430	80	280	90	205	840	490	24	7,07
	45	225M	790	225	595	43	1428	610	605	1250	480	100	325	90	205	840	550	28	8,07
	55	250M	890	250	595	42	1527	540	610	1400	430	80	330	90	230	940	490	27	7,08
	75	280S	958	280	595	43	1596	730	660	1400	660	100	380	90	230	940	670	28	10,08

NM End Suction Centrifugal Pumps

Performance Curves 50 Hz

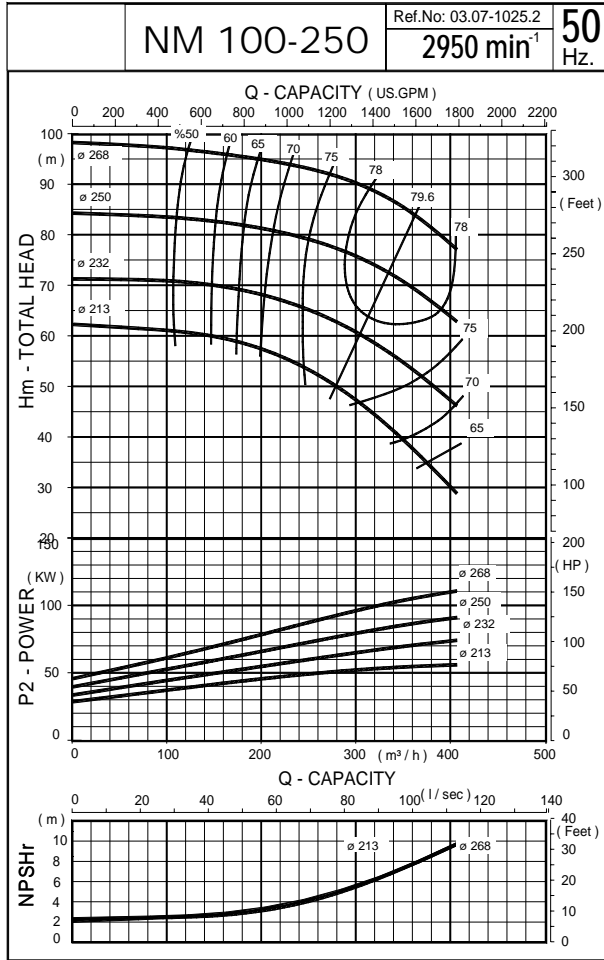
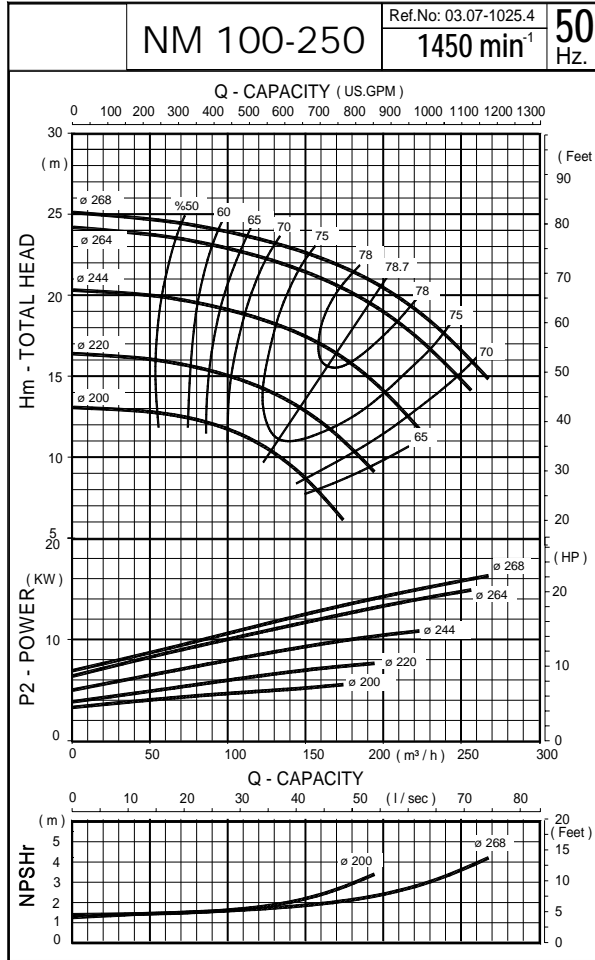

The Performance Curves 50 Hz are based on the kinematic viscosity 1 mm²/s and density 1g/cm³. Tolerances are acc. to ISO 9906 Annex A.

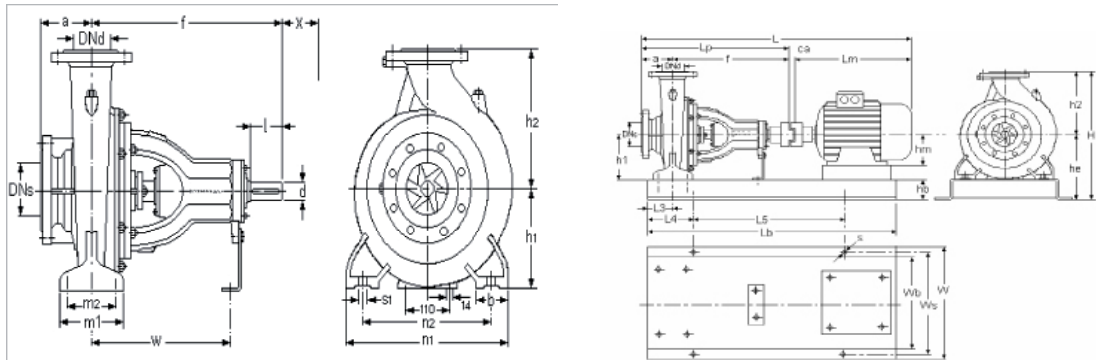

Pump size	Flanges		Length		Height		Mounting details						Shaft end		(*) X mm	Weight kg	
	DNb mm	DNd mm	a mm	f mm	h1 mm	h2 mm	b mm	m1 mm	m2 mm	n1 mm	n2 mm	s1 mm	W mm	d mm			l mm
100-250	125	100	140	470	225	280	80	160	120	400	315	M16	340	32	80	130	95

	MOTOR			PUMP			GENERAL				BASEPLATE								
	KW	IEC	Lm mm	Hm mm	Lp mm	Ca mm	L mm	W mm	H mm	Lb mm	Wb mm	Hb mm	He mm	L3 mm	L4 mm	L5 mm	Ws mm	S mm	Plate No
100-250 4 poles 50Hz	5,5	132S	455	132	610	26	1095	540	585	1000	430	80	305	90	170	660	490	24	7,05
	7,5	132M	493	132	610	26	1129	540	585	1000	430	80	305	90	170	660	490	24	7,05
	9	C132M	493	132	610	26	1129	540	585	1000	430	80	305	90	170	660	490	24	7,05
	11	160M	594	160	610	30	1234	540	585	1120	430	80	305	90	190	740	490	24	7,06
	15	160L	638	160	610	30	1278	540	585	1120	430	80	305	90	190	740	490	24	7,06
	18,5	180M	654	180	610	33	1297	540	585	1120	430	80	305	90	190	740	490	24	7,06
100-250 2 poles 50Hz	55	250M	890	250	610	42	1542	540	610	1400	430	80	330	90	230	940	490	24	7,08
	75	280S	958	280	610	43	1611	730	660	1400	600	100	380	90	230	940	670	28	10,08
	90	280M	1010	280	630	43	1663	730	660	1600	600	100	380	90	270	1660	670	28	10,09
	110	315S	1078	315	610	43	1731	830	715	1600	600	120	435	90	270	1660	766	33	11,09

NM End Suction Centrifugal Pumps

Performance Curves 50 Hz

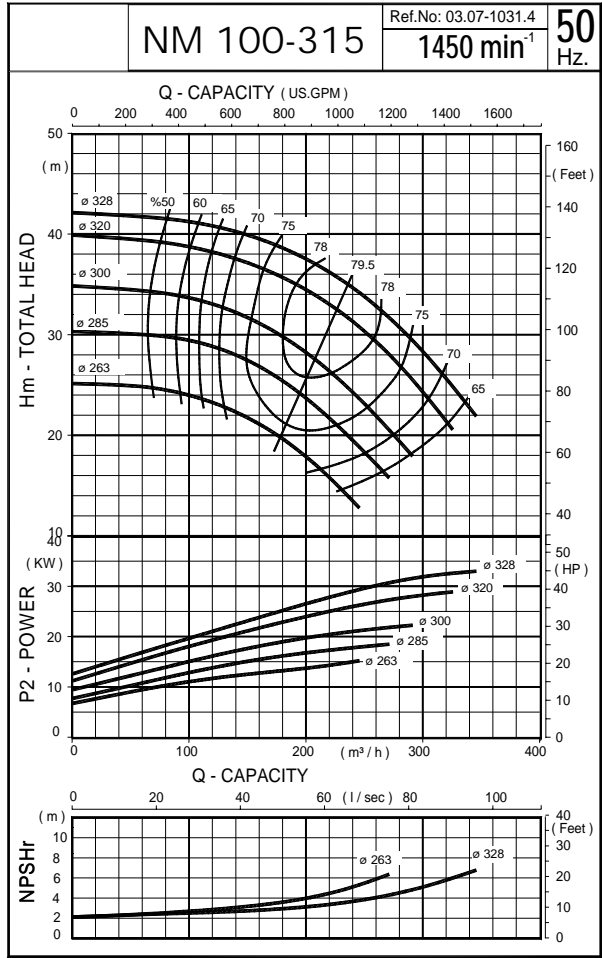
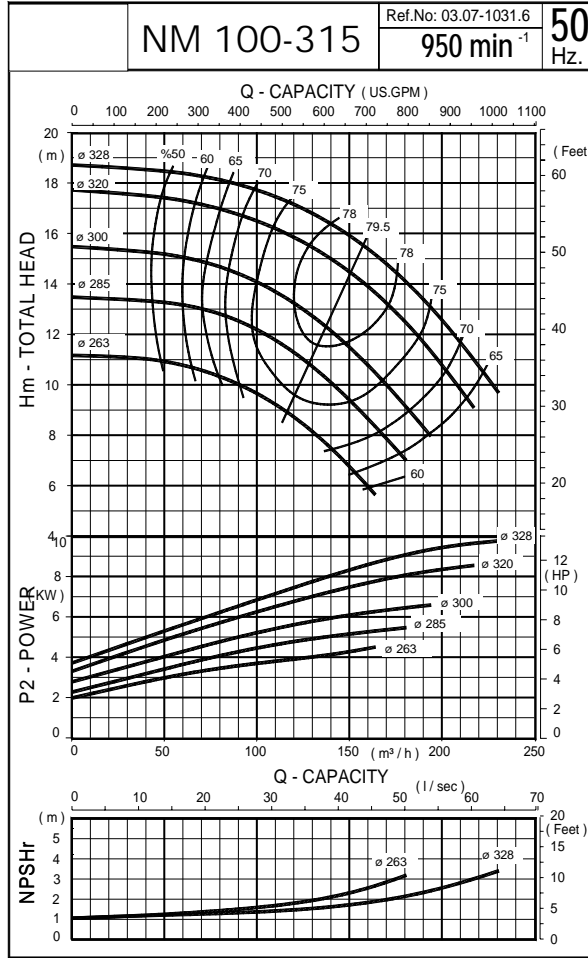

The Performance Curves 50 Hz are based on the kinematic viscosity 1 mm²/s and density 1g/cm³. Tolerances are acc. to ISO 9906 Annex A.

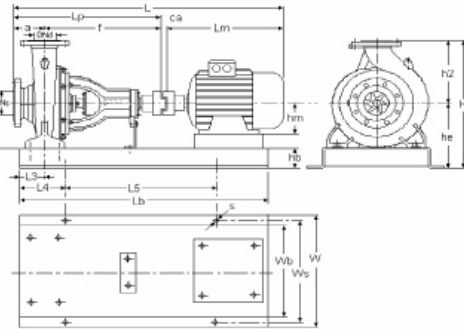
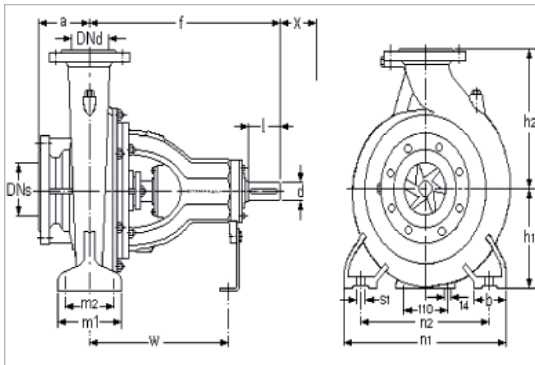

Pump size	Flanges		Length		Height		Mounting details						Shaft end		(*) X mm	Weight kg	
	DNs mm	DNd mm	a mm	f mm	h1 mm	h2 mm	b mm	m1 mm	m2 mm	n1 mm	n2 mm	s1 mm	W mm	d mm			l mm
100-315	125	100	140	470	250	315	80	160	120	400	315	M16	340	32	80	130	110

	MOTOR			PUMP		GENERAL				BASEPLATE									
	KW	IEC	Lm mm	Hm mm	Lp mm	Ca mm	L mm	W mm	H mm	Lb mm	Wb mm	Hb mm	He mm	L3 mm	L4 mm	L5 mm	Ws mm	S mm	Plate No
100-315 6 poles 50 Hz	4	132M	493	132	610	26	1129	540	645	1000	430	80	330	90	170	660	490	24	7.05
	5,5	132M	493	132	610	26	1129	540	645	1000	430	80	330	90	170	660	490	24	7.05
	7,5	160M	594	160	610	30	1234	540	645	1120	430	80	330	90	190	740	490	24	7.06
	11	160L	638	160	610	33	1281	540	645	1120	430	80	330	90	190	740	490	24	7.06
100-315 4 poles 50 Hz	15	160L	638	160	610	30	1278	540	645	1120	430	80	330	90	190	740	490	24	7.06
	18,5	180M	654	180	610	33	1297	540	645	1120	430	80	330	90	190	740	490	24	7.06
	22	180L	692	180	610	33	1335	540	645	1250	430	80	330	90	205	840	490	24	7.07
	30	200L	747	200	610	42	1399	540	645	1250	430	80	330	90	205	840	490	24	7.07
	37	225S	695	225	610	43	1448	610	665	1250	480	100	350	90	205	840	550	28	8.07

NM End Suction Centrifugal Pumps

Performance Curves 50 Hz

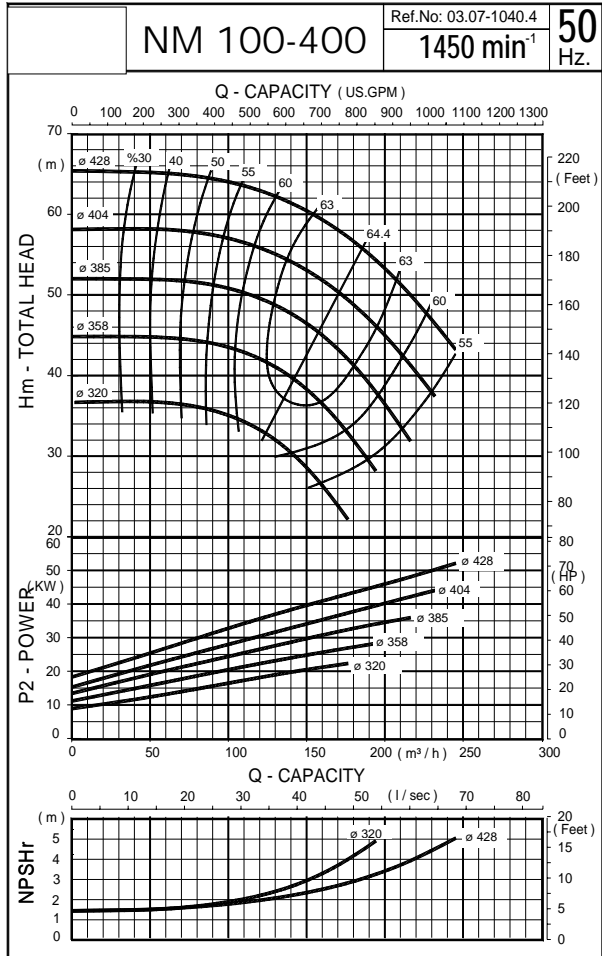
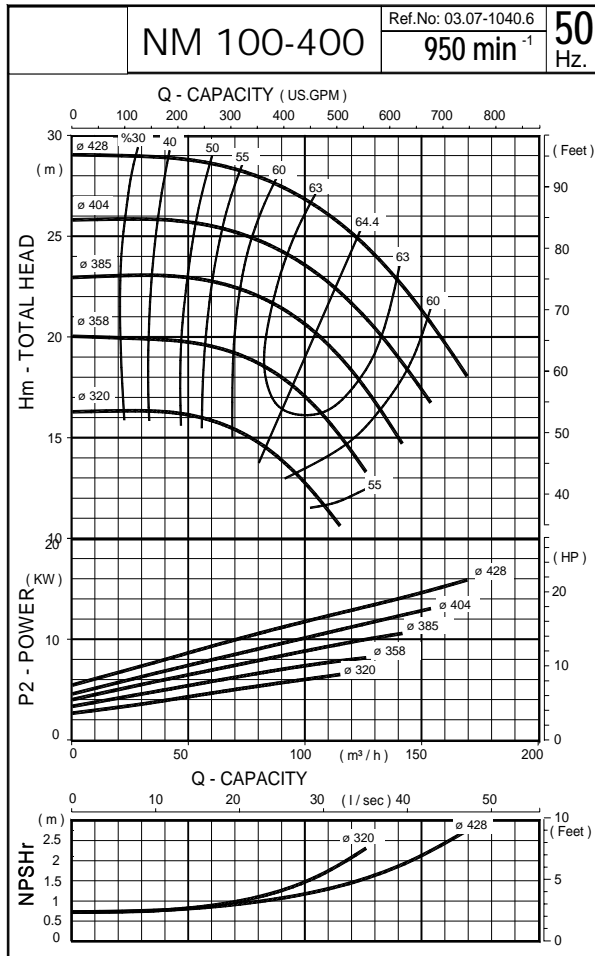

The Performance Curves 50 Hz are based on the kinematic viscosity 1 mm²/s and density 1g/cm³. Tolerances are acc. to ISO 9906 Annex A.

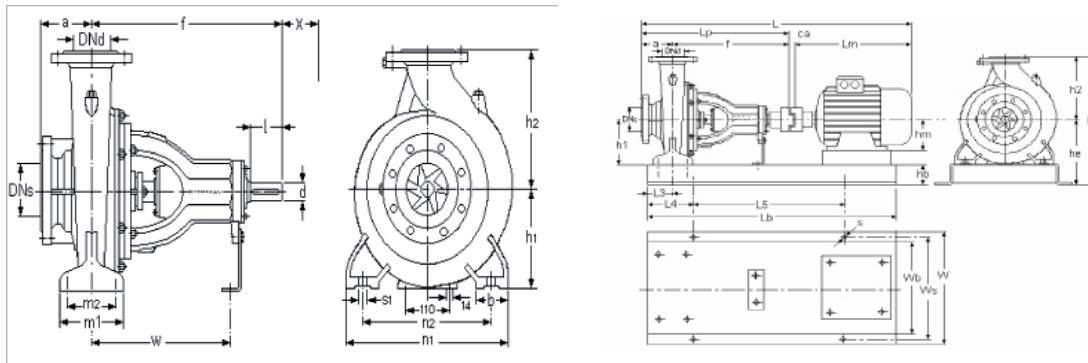

Pump size	Flanges		Length		Height		Mounting details						Shaft end		(*) X mm	Weight kg	
	DNs mm	DNd mm	a mm	f mm	h1 mm	h2 mm	b mm	m1 mm	m2 mm	n1 mm	n2 mm	s1 mm	W mm	d mm			l mm
100-400	125	100	140	530	280	355	100	200	150	500	400	M20	370	42	110	130	168

	MOTOR			PUMP		GENERAL			BASEPLATE										
	KW	IEC	Lm mm	Hm mm	Lp mm	Ca mm	L mm	W mm	H mm	Lb mm	Wb mm	Hb mm	He mm	L3 mm	L4 mm	L5 mm	Ws mm	S mm	Plate No
100-400 6 poles 50Hz	7.5	160M	594	160	670	30	1294	660	735	1250	530	100	380	110	205	840	600	28	9.07
	11	160L	638	160	670	33	1341	660	735	1400	530	100	380	110	205	840	600	28	9.07
	15	180L	692	180	670	33	1395	660	735	1250	530	100	380	110	205	840	600	28	9.07
100-400 4 poles 50Hz	22	180L	692	180	670	33	1395	660	735	1250	530	100	380	110	205	840	600	28	9.07
	30	200L	747	200	670	42	1459	660	735	1400	530	100	380	110	230	940	600	28	9.08
	37	225S	795	225	670	43	1508	660	735	1400	530	100	380	110	230	940	600	28	9.08
	45	225M	820	225	670	43	1533	660	735	1400	530	100	380	110	230	940	600	28	9.08
	55	250M	890	250	670	43	1603	660	735	1400	530	100	380	110	230	940	600	28	9.08

NM End Suction Centrifugal Pumps

Performance Curves 50 Hz

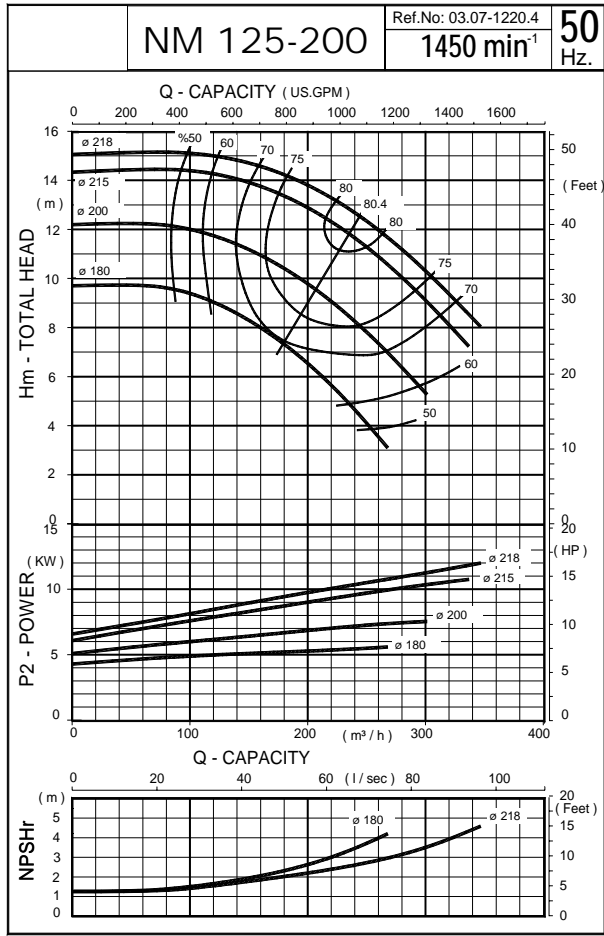
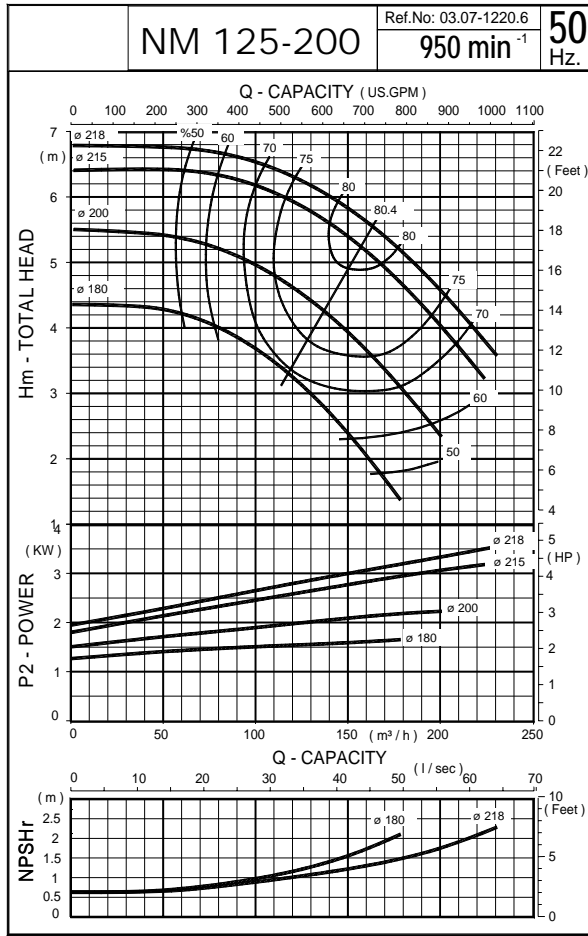

The Performance Curves 50 Hz are based on the kinematic viscosity 1 mm²/s and density 1g/cm³. Tolerances are acc. to ISO 9906 Annex A.

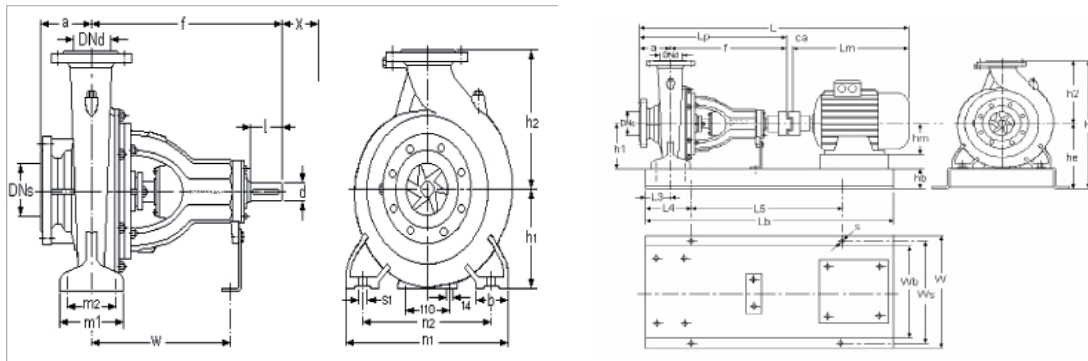

Pump size	Flanges		Length		Height		Mounting details							Shaft end		(*) X mm	Weight kg
	DNs mm	DNd mm	a mm	f mm	h1 mm	h2 mm	b mm	m1 mm	m2 mm	n1 mm	n2 mm	s1 mm	W mm	d mm	l mm		
125-200	150	125	140	470	250	315	80	160	120	400	315	M16	340	32	80	130	106.5

	MOTOR			PUMP			GENERAL				BASEPLATE									
	KW	IEC	Lm mm	Hm mm	Lp mm	Ca mm	L mm	W mm	H mm	Lb mm	Wb mm	Hb mm	He mm	L3 mm	L4 mm	L5 mm	Ws mm	S mm	Plate No	
125-200 6 poles 50 Hz	1,5	100L	365	100	610	20	995	540	645	900	430	80	330	90	150	600	490	24	7.04	
	2,2	112M	384	112	610	21	1015	540	645	900	430	80	330	90	150	600	490	24	7.04	
	3	132S	455	132	610	21	1086	540	645	1000	430	80	330	90	170	660	490	24	7.05	
	4	132M	493	132	610	26	1129	540	645	1000	430	80	330	90	170	660	490	24	7.05	
125-200 4 poles 50 Hz	5,5	132S	455	132	610	26	1091	540	645	1000	430	80	330	90	170	660	490	24	7.05	
	7,5	132M	493	132	610	26	1129	540	645	1000	430	80	330	90	170	660	490	24	7.05	
	9	C132M	493	132	610	26	1129	540	645	1000	430	80	330	90	170	660	490	24	7.05	
	11	160M	594	160	610	30	1234	540	645	1120	430	80	330	90	190	740	490	24	7.06	
	15	160L	638	160	610	38	1278	540	645	1120	430	80	330	90	190	740	490	24	7.06	

NM End Suction Centrifugal Pumps

Performance Curves 50 Hz

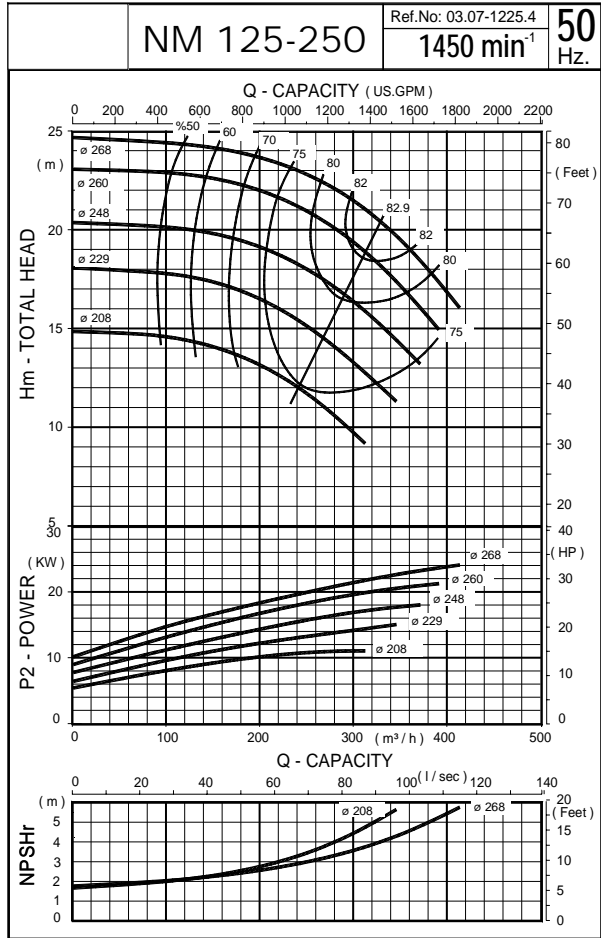
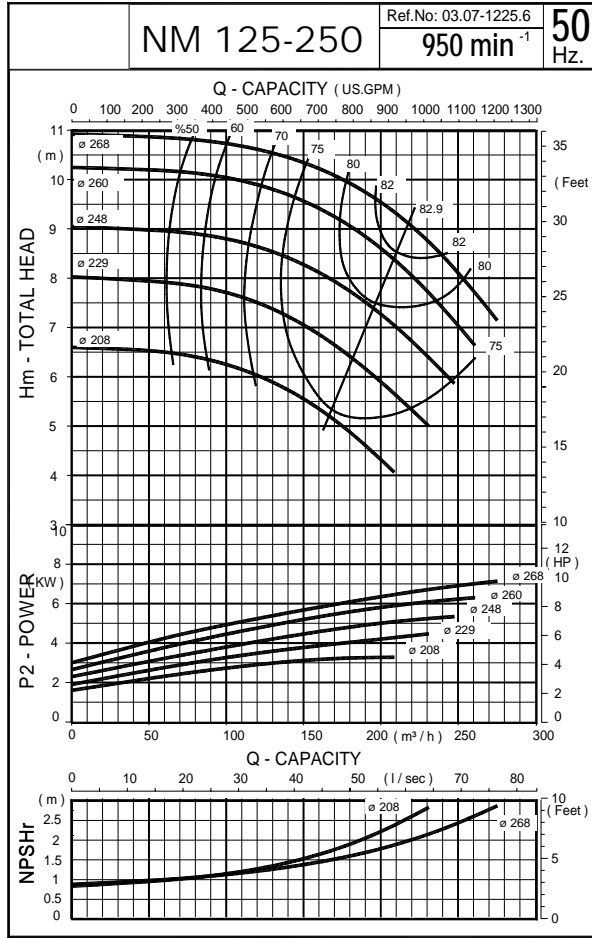

The Performance Curves 50 Hz are based on the kinematic viscosity 1 mm²/s and density 1g/cm³. Tolerances are acc. to ISO 9906 Annex A.

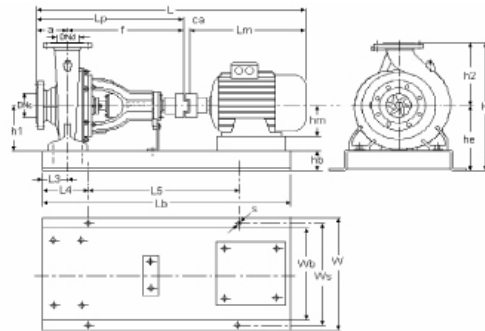
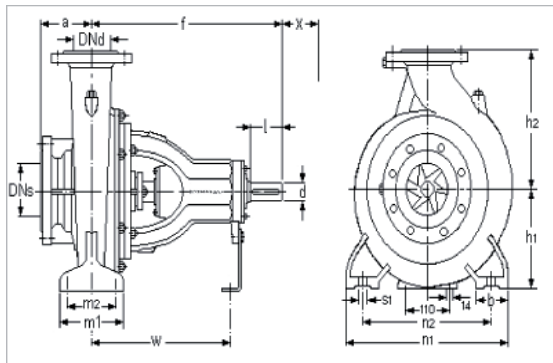

Pump size	Flanges		Length		Height		Mounting details							Shaft end		(*) X mm	Weight kg
	DNs mm	DNd mm	a mm	f mm	h1 mm	h2 mm	b mm	m1 mm	m2 mm	n1 mm	n2 mm	s1 mm	W mm	d mm	l mm		
125-250	150	125	140	470	250	355	80	160	120	400	315	M16	340	32	80	140	105,5

	MOTOR			PUMP		GENERAL				BASEPLATE									
	KW	IEC	Lm mm	Hm mm	Lp mm	Ca mm	L mm	W mm	H mm	Lb mm	Wb mm	Hb mm	He mm	L3 mm	L4 mm	L5 mm	Ws mm	S mm	Plate No
125-250 6 poles 50 Hz	3	132S	455	132	610	21	1086	540	685	1000	430	80	330	90	170	660	490	24	7.05
	4	132M	493	132	610	26	1129	540	685	1000	430	80	330	90	170	660	490	24	7.05
	5,5	132M	493	132	610	26	1129	540	685	1000	430	80	330	90	170	660	490	24	7.05
	7,5	160M	594	160	610	30	1234	540	685	1120	430	80	330	90	190	740	490	24	7.06
125-250 4 poles 50 Hz	11	160M	594	160	610	30	1234	540	685	1120	430	80	330	90	190	740	490	24	7.06
	15	160L	638	160	610	30	1278	540	685	1120	430	80	330	90	190	740	490	24	7.06
	18,5	180M	654	180	610	33	1297	540	685	1120	430	80	330	90	190	740	490	24	7.06
	22	180L	692	180	610	33	1335	540	685	1250	430	80	330	90	205	840	490	24	7.07
	30	200L	747	200	610	42	1399	540	685	1250	430	80	330	90	205	840	490	24	7.07

NM End Suction Centrifugal Pumps

Performance Curves 50 Hz

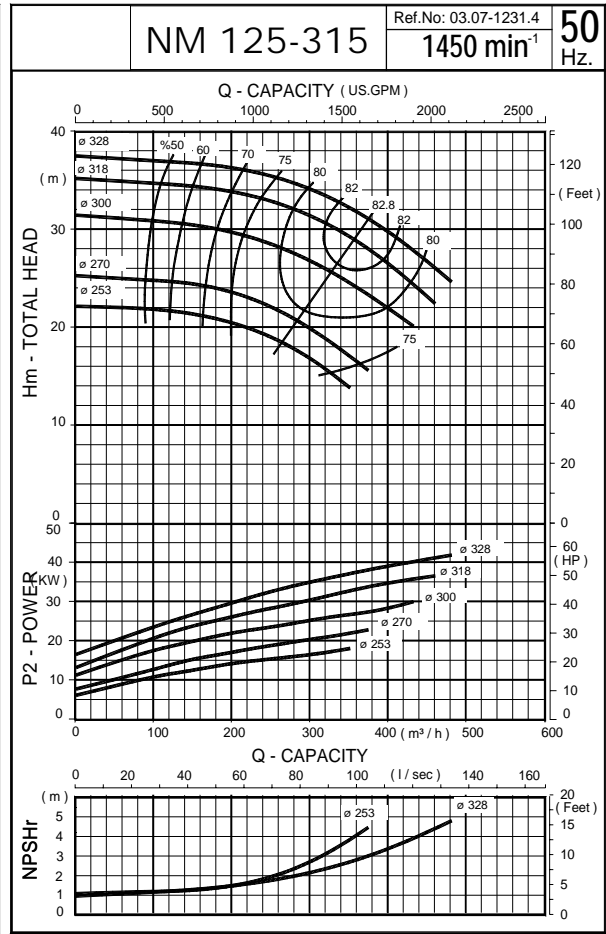
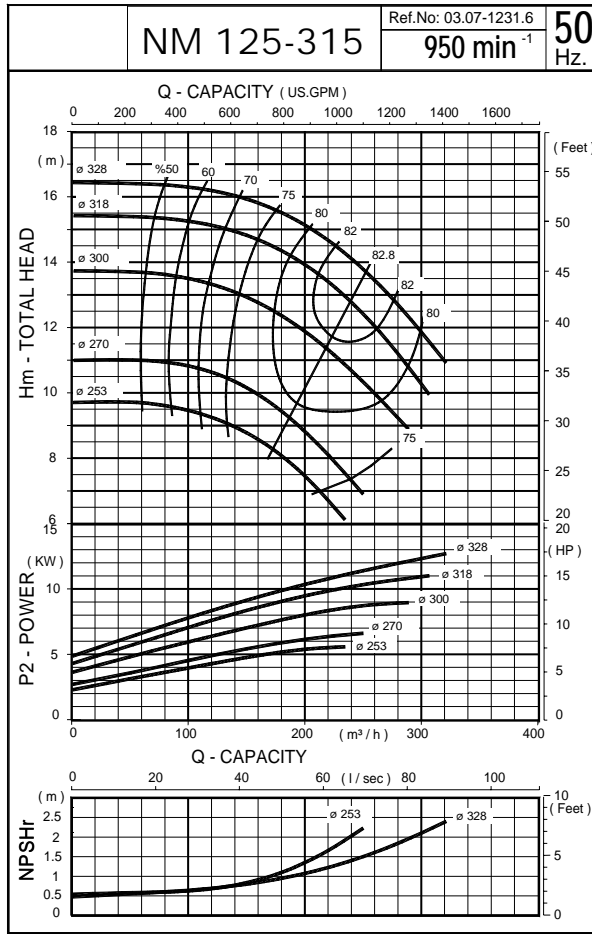

The Performance Curves 50 Hz are based on the kinematic viscosity 1 mm²/s and density 1g/cm³. Tolerances are acc. to ISO 9906 Annex A.

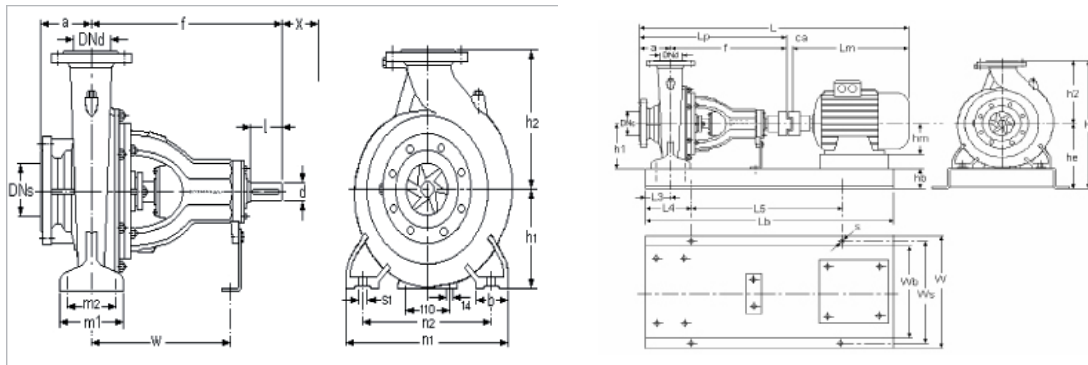

Pump size	Flanges		Length		Height		Mounting details						Shaft end		(*) X mm	Weight kg	
	DNs mm	DNd mm	a mm	f mm	h1 mm	h2 mm	b mm	m1 mm	m2 mm	n1 mm	n2 mm	s1 mm	W mm	d mm			l mm
125-315	150	125	140	530	280	355	100	200	150	500	400	M20	370	42	110	140	166,5

	MOTOR			PUMP			GENERAL			BASEPLATE									
	KW	IEC	Lm mm	Hm mm	Lp mm	Ca mm	L mm	W mm	H mm	Lb mm	Wb mm	Hb mm	He mm	L3 mm	L4 mm	L5 mm	Ws mm	S mm	Plate No
125-315 6 poles 50 Hz	5,5	132M	493	132	670	26	1189	660	735	1120	530	100	380	110	190	740	600	28	9.06
	7,5	160M	594	160	670	30	1294	660	735	1250	530	100	380	110	205	840	600	28	9.07
	11	160L	638	160	670	33	1341	660	735	1250	530	100	380	110	205	840	600	28	9.07
	15	180L	692	180	670	33	1395	660	735	1250	530	100	380	110	205	840	600	28	9.07
125-315 4 poles 50 Hz	18,5	180M	654	180	670	33	1357	660	735	1250	530	100	380	110	205	840	600	28	9.08
	22	180L	692	180	670	33	1395	660	735	1250	530	100	380	110	205	840	600	28	9.08
	30	200L	747	200	670	42	1459	660	735	1400	530	100	380	110	230	940	600	28	9.08
	37	225S	795	225	670	43	1508	660	735	1400	530	100	380	110	230	940	600	28	9.08
	45	225M	820	225	670	43	1533	660	735	1400	530	100	380	110	230	940	600	28	9.08



WATER PUMPS

NM End Suction Centrifugal Pumps

Performance Curves 50 Hz

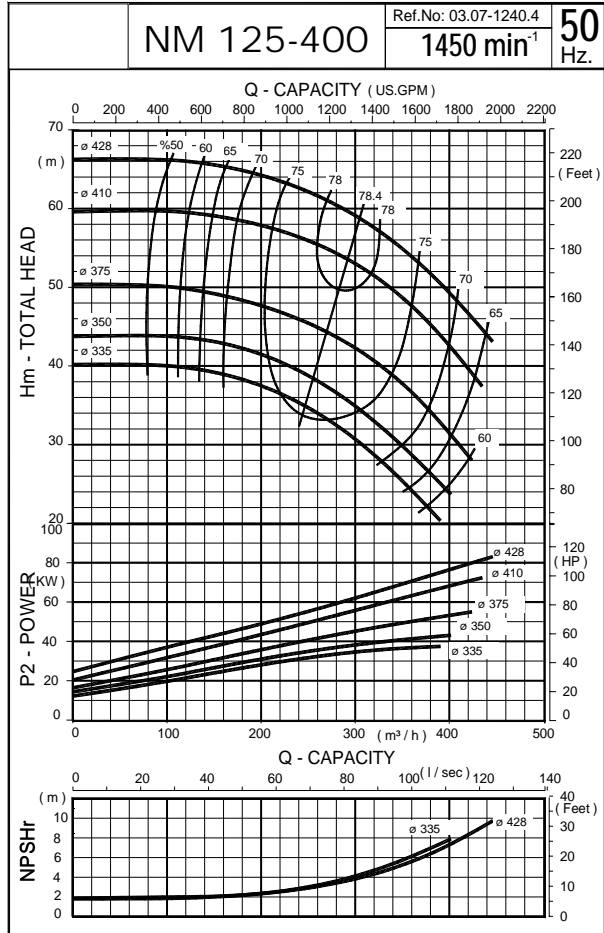
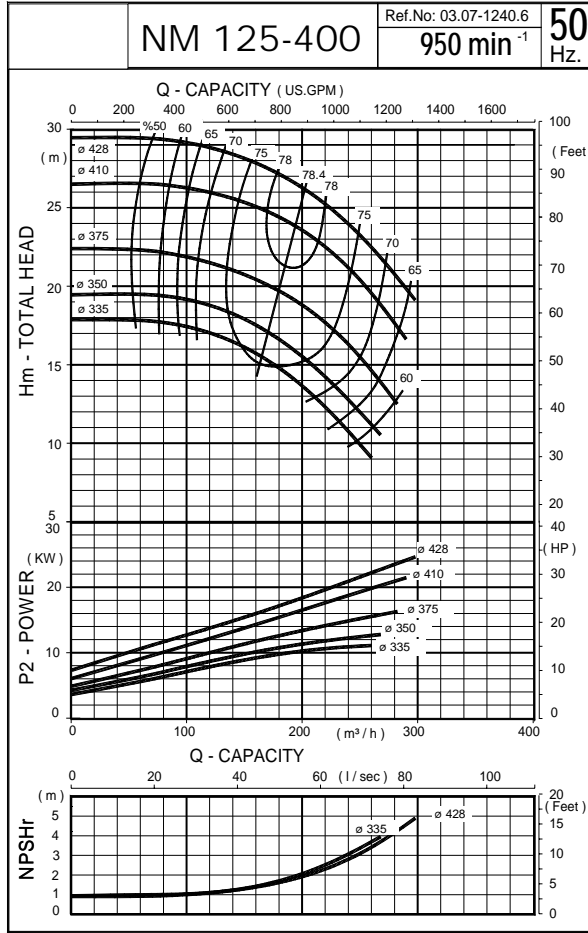

The Performance Curves 50 Hz are based on the kinematic viscosity 1 mm²/s and density 1g/cm³. Tolerances are acc. to ISO 9906 Annex A.

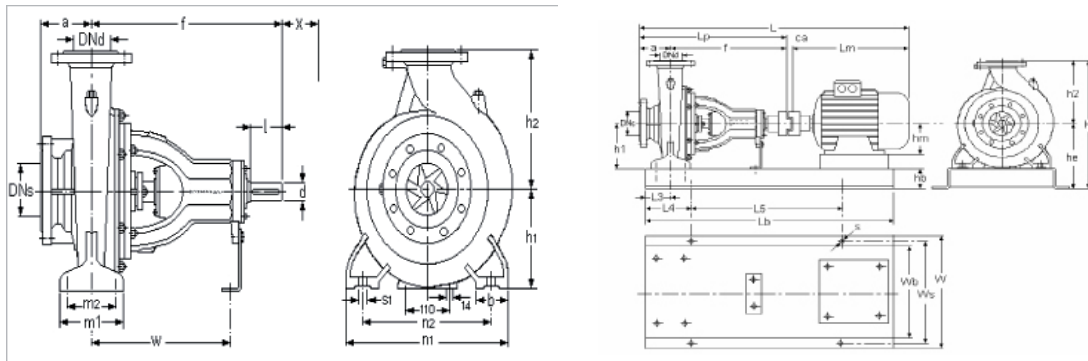

Pump size	Flanges		Length		Height		Mounting details							Shaft end		(*) X mm	Weight kg
	DNs mm	DNd mm	a mm	f mm	h1 mm	h2 mm	b mm	m1 mm	m2 mm	n1 mm	n2 mm	s1 mm	W mm	d mm	l mm		
125-400	150	125	140	530	315	400	100	200	150	500	400	M20	370	42	110	140	189

	MOTOR			PUMP		GENERAL				BASEPLATE									
	KW	IEC	Lm mm	Hm mm	Lp mm	Ca mm	L mm	W mm	H mm	Lb mm	Wb mm	Hb mm	He mm	L3 mm	L4 mm	L5 mm	Ws mm	S mm	Plate No
125-400 6 poles 50 Hz	11	160L	638	160	670	33	1341	660	815	1250	530	100	415	110	205	840	600	28	9.07
	15	180L	692	180	670	33	1395	660	815	1250	530	100	415	110	205	840	600	28	9.07
	18,5	200L	747	200	670	42	1459	660	815	1400	530	100	415	110	230	940	600	28	9.08
	22	200L	747	200	670	42	1459	660	815	1400	530	100	415	110	230	940	600	28	9.08
	30	225M	820	225	670	42	1532	660	815	1400	530	100	415	110	230	940	600	28	9.08
125-400 4 poles 50 Hz	37	225S	795	225	670	43	1508	660	815	1400	530	100	415	110	230	940	600	28	9.08
	45	225M	820	225	670	43	1533	660	815	1400	530	100	415	110	230	940	600	28	9.08
	55	250M	890	250	670	43	1603	660	815	1400	530	100	415	110	230	940	600	28	9.08
	75	280S	958	280	670	43	1671	730	815	1600	600	100	415	110	270	1060	670	28	10,09
	90	280M	1010	280	670	43	1723	730	815	1600	600	100	415	110	270	1060	670	28	10,09

NM End Suction Centrifugal Pumps

Performance Curves 50 Hz

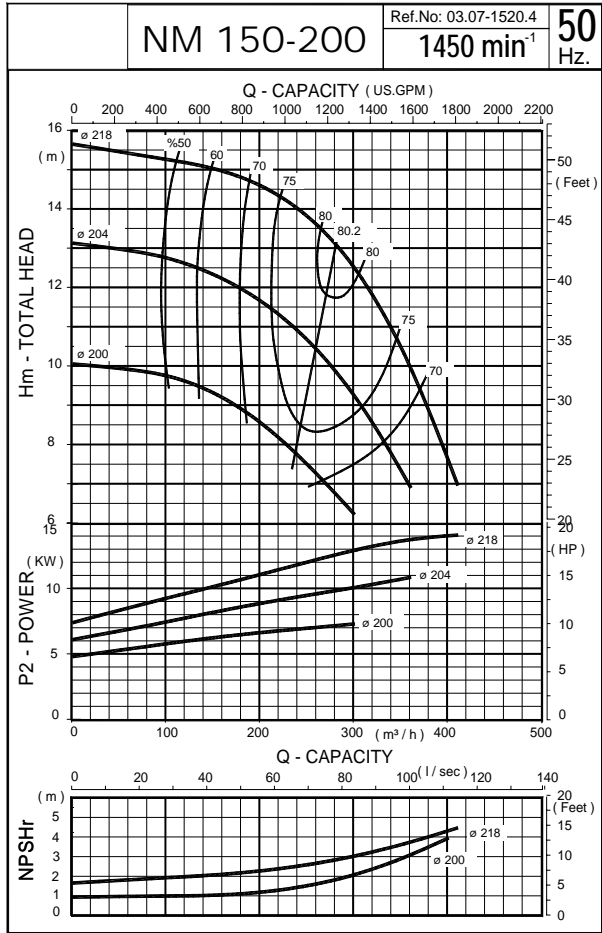
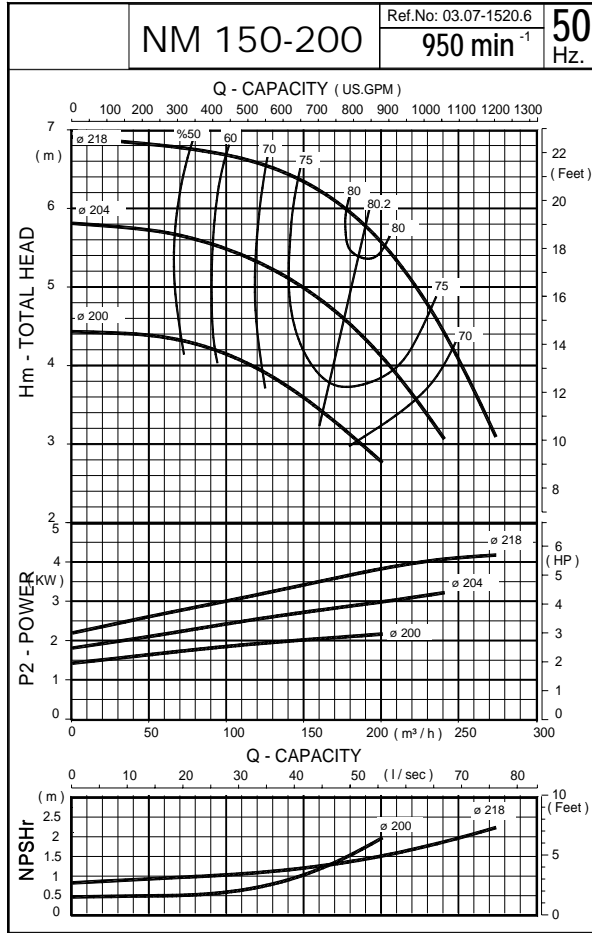

The Performance Curves 50 Hz are based on the kinematic viscosity 1 mm²/s and density 1g/cm³. Tolerances are acc. to ISO 9906 Annex A.

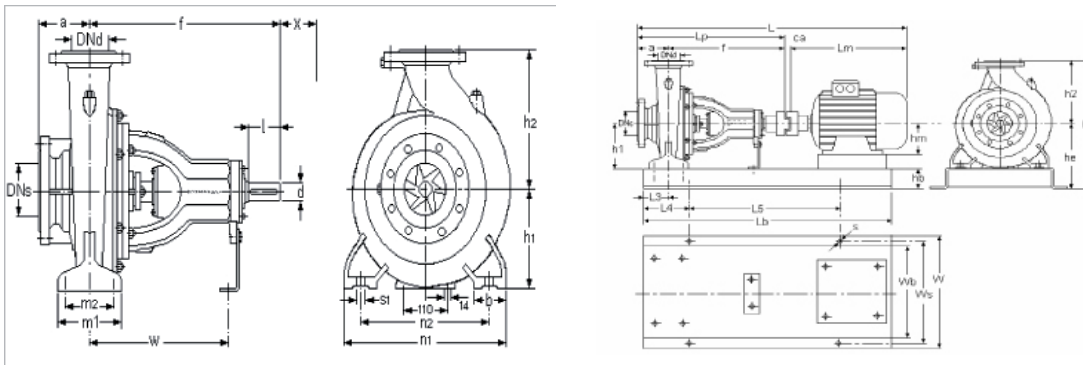

Pump size	Flanges		Length		Height		Mounting details							Shaft end		(*) X mm	Weight kg
	DNs mm	DNd mm	a mm	f mm	h1 mm	h2 mm	b mm	m1 mm	m2 mm	n1 mm	n2 mm	s1 mm	W mm	d mm	l mm		
150-200	200	150	160	470	280	355	100	200	150	500	400	M16	340	32	80	170	137.5

	MOTOR			PUMP		GENERAL			BASEPLATE										
	KW	IEC	Lm mm	Hm mm	Lp mm	Ca mm	L mm	W mm	H mm	Lb mm	Wb mm	Hb mm	He mm	L3 mm	L4 mm	L5 mm	Ws mm	S mm	Plate No
150-200 6 poles 50 Hz	2,2	112M	384	112	630	21	1035	660	735	900	530	100	380	110	150	600	600	28	9.04
	3	132S	455	132	630	21	1106	660	735	1000	530	100	380	110	170	660	600	28	9.05
	4	132M	493	132	630	26	1149	660	735	1000	530	100	380	110	170	660	600	28	9.05
	5,5	132M	493	132	630	26	1149	660	735	1000	530	100	380	110	170	660	600	28	9.05
150-200 4 poles 50 Hz	7,5	132M	493	132	630	26	1149	660	735	1000	530	100	380	110	170	660	600	28	9.05
	9	C132M	493	132	630	26	1149	660	735	1000	530	100	380	110	170	660	600	28	9.05
	11	160M	594	160	630	30	1254	660	735	1120	530	100	380	110	190	740	600	28	9.06
	15	160L	638	160	630	30	1298	660	735	1120	530	100	380	110	190	740	600	28	9.06

NM End Suction Centrifugal Pumps

Performance Curves 50 Hz

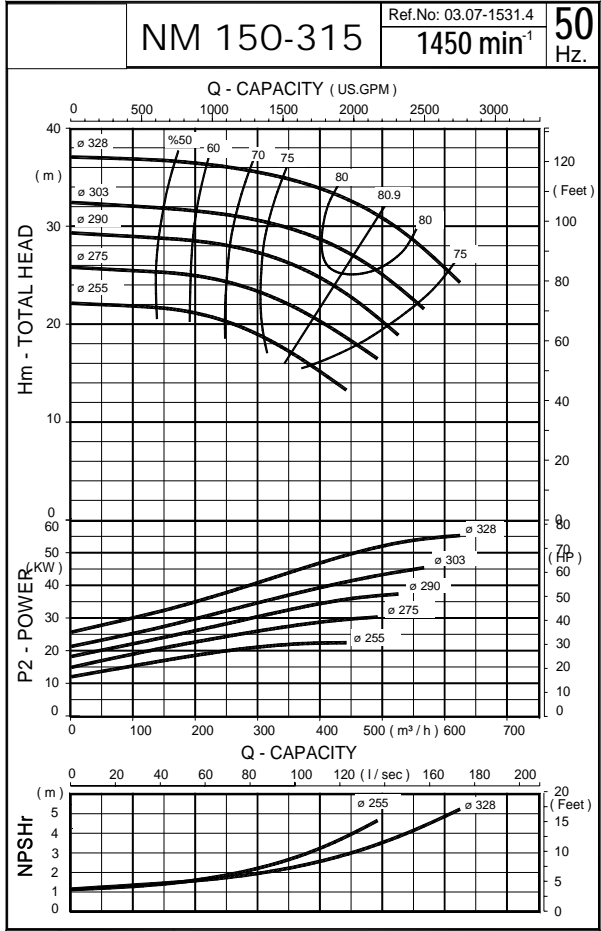
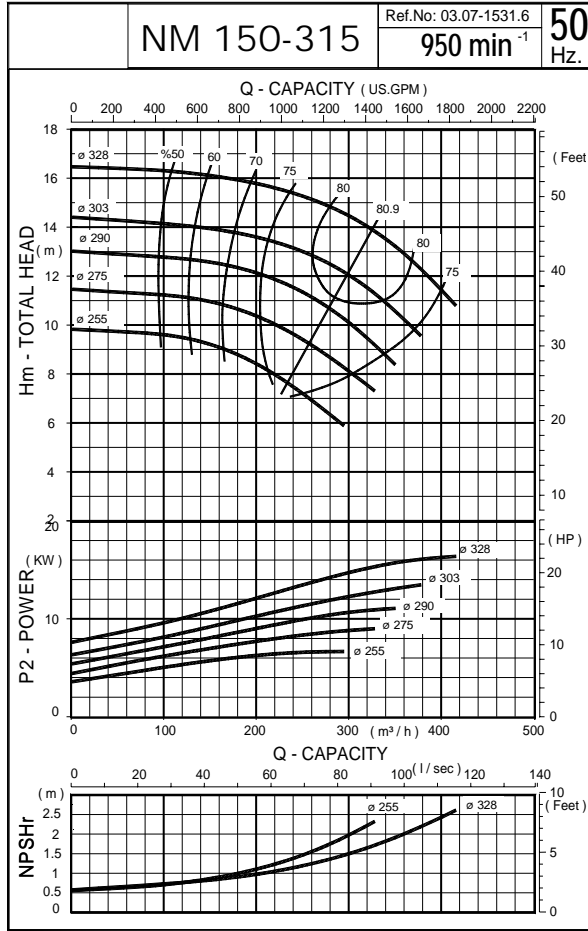

The Performance Curves 50 Hz are based on the kinematic viscosity 1 mm²/s and density 1g/cm³. Tolerances are acc. to ISO 9906 Annex A.

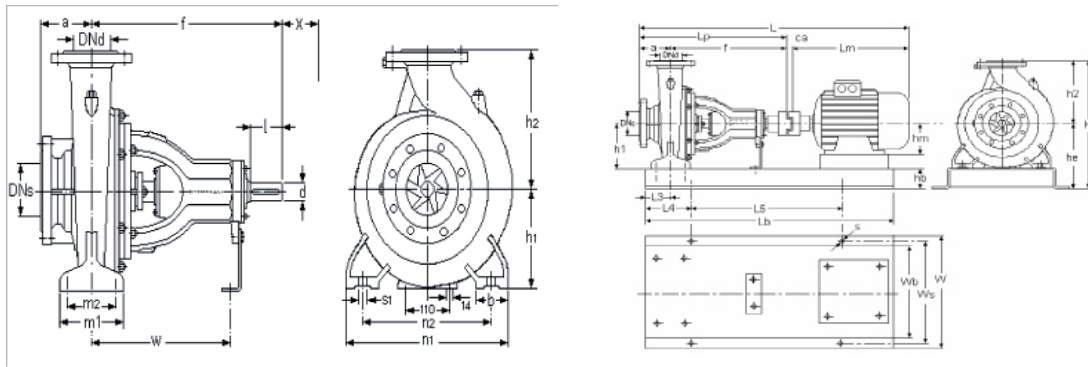

Pump size	Flanges		Length		Height		Mounting details						Shaft end		(*) X mm	Weight kg	
	DNs mm	DNd mm	a mm	f mm	h1 mm	h2 mm	b mm	m1 mm	m2 mm	n1 mm	n2 mm	s1 mm	W mm	d mm			l mm
150-315	200	150	160	530	280	400	100	200	150	550	450	M20	370	42	110	140	182.5

	MOTOR			PUMP		GENERAL			BASEPLATE										
	KW	IEC	Lm mm	Hm mm	Lp mm	Ca mm	L mm	W mm	H mm	Lb mm	Wb mm	Hb mm	He mm	L3 mm	L4 mm	L5 mm	Ws mm	S mm	Plate No
150-315 6 poles 50 Hz	7.5	160M	594	160	690	30	1314	730	780	1250	600	100	380	110	205	840	670	28	10.07
	11	160L	638	160	690	33	1361	730	780	1250	600	100	380	110	205	840	670	28	10.07
	15	180L	692	180	690	33	1415	730	780	1250	600	100	380	110	205	840	670	28	10.07
	18.5	200L	747	200	690	42	1479	730	780	1400	600	100	380	110	230	940	670	28	10.08
150-315 4 poles 50 Hz	22	180L	692	180	690	33	1415	730	780	1250	600	100	380	110	205	840	670	28	10.07
	30	200L	747	200	690	42	1479	730	780	1400	600	100	380	110	230	940	670	28	10.08
	37	225S	795	225	690	43	1528	730	780	1400	600	100	380	110	230	940	670	28	10.08
	45	225M	840	225	690	43	1553	730	780	1400	600	100	380	110	230	940	670	28	10.08
	55	250M	890	250	690	43	1623	730	780	1400	600	100	380	110	230	940	670	28	10.08

NM End Suction Centrifugal Pumps

Performance Curves 50 Hz

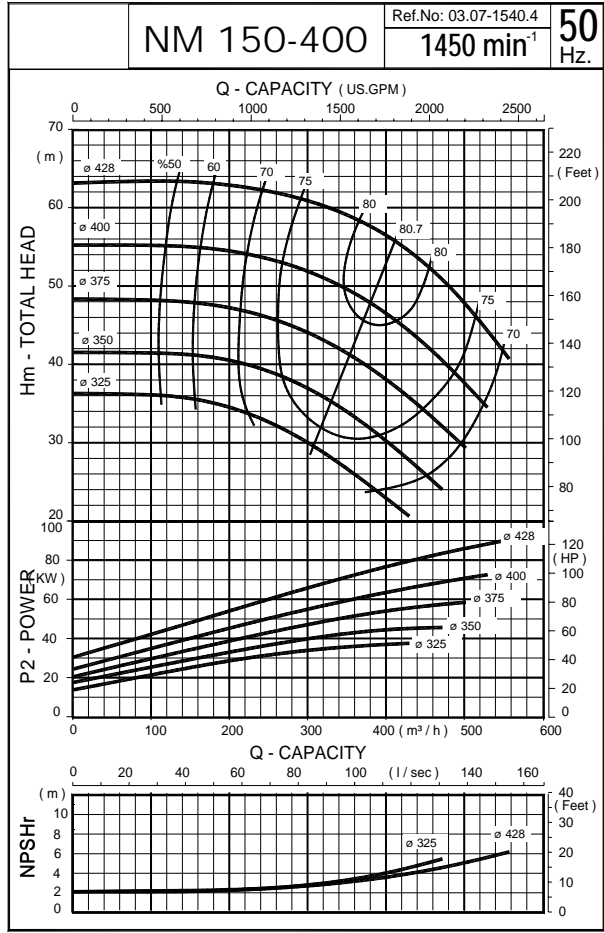
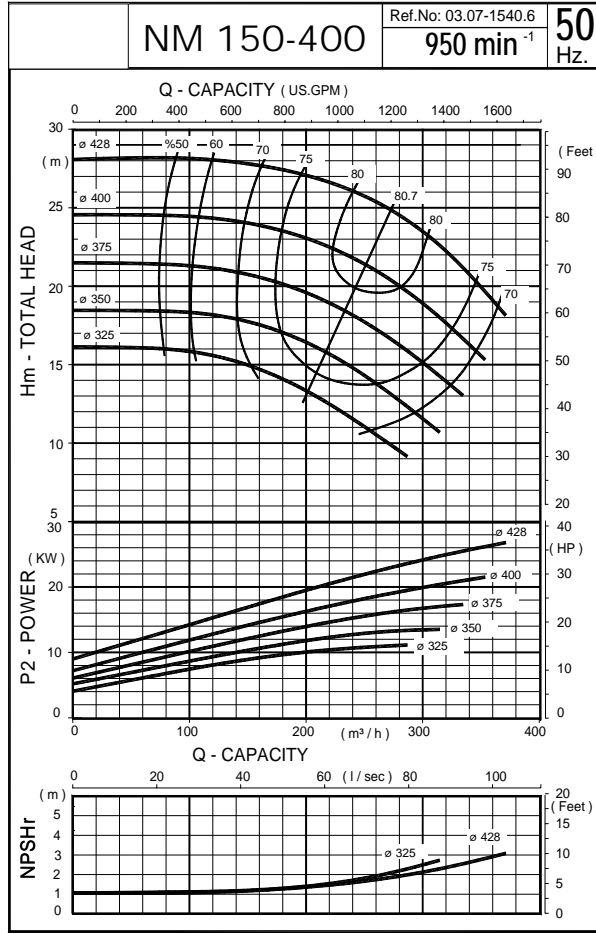

The Performance Curves 50 Hz are based on the kinematic viscosity 1 mm²/s and density 1g/cm³. Tolerances are acc. to ISO 9906 Annex A.

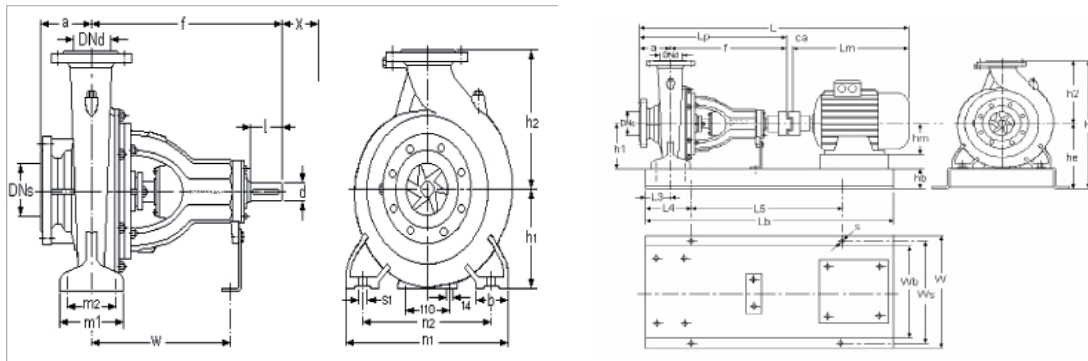

Pump size	Flanges		Length		Height		Mounting details							Shaft end		(*) X mm	Weight kg
	DNs mm	DNd mm	a mm	f mm	h1 mm	h2 mm	b mm	m1 mm	m2 mm	n1 mm	n2 mm	s1 mm	W mm	d mm	l mm		
150-400	200	150	160	530	315	450	100	200	150	550	450	M20	370	42	110	140	210.5

	MOTOR			PUMP		GENERAL			BASEPLATE										
	KW	IEC	Lm mm	Hm mm	Lp mm	Ca mm	L mm	W mm	H mm	Lb mm	Wb mm	Hb mm	He mm	L3 mm	L4 mm	L5 mm	Ws mm	S mm	Plate No
150-400 6 poles 50 Hz	11	160L	638	160	690	33	1361	730	865	1250	600	100	415	110	205	840	670	28	10.07
	15	180L	692	180	690	33	1415	730	865	1250	600	100	415	110	205	840	670	28	10.07
	18,5	200L	747	200	690	42	1479	730	865	1400	600	100	415	110	230	940	670	28	10.08
	22	200L	747	200	690	42	1479	730	865	1400	600	100	415	110	230	940	670	28	10.08
	30	225M	820	225	690	42	1552	730	865	1400	600	100	415	110	230	940	670	28	10.08
150-400 4 poles 50 Hz	45	225M	820	225	690	43	1553	730	865	1400	600	100	415	110	230	940	670	28	10.08
	55	250M	890	250	690	43	1623	730	865	1400	600	100	415	110	230	940	670	28	10.08
	75	280S	958	280	690	43	1691	730	865	1600	600	100	415	110	270	1060	670	28	10.09
	90	280M	1010	280	690	43	1743	730	865	1600	600	100	415	110	270	1060	670	28	10.09

NM End Suction Centrifugal Pumps

Performance Curves 50 Hz

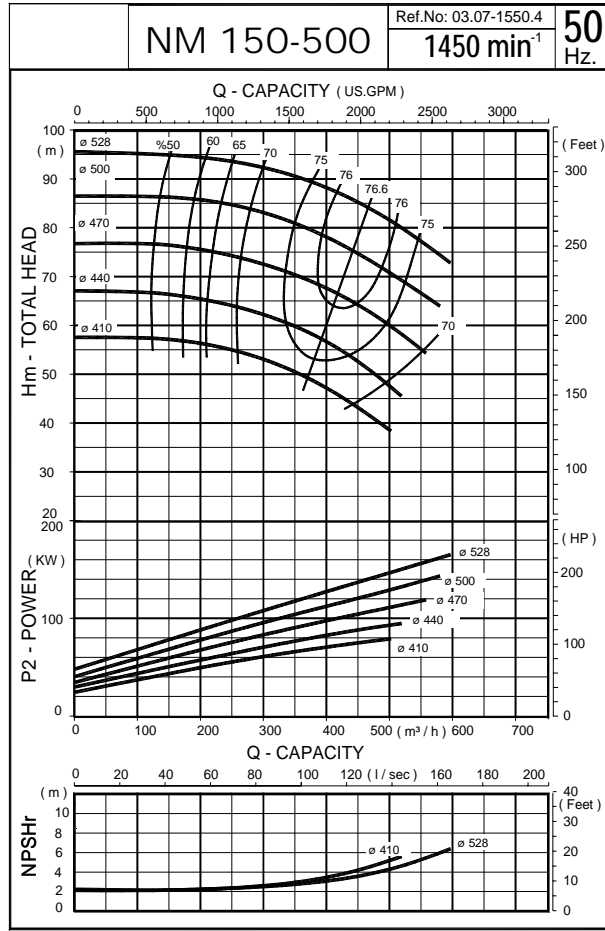
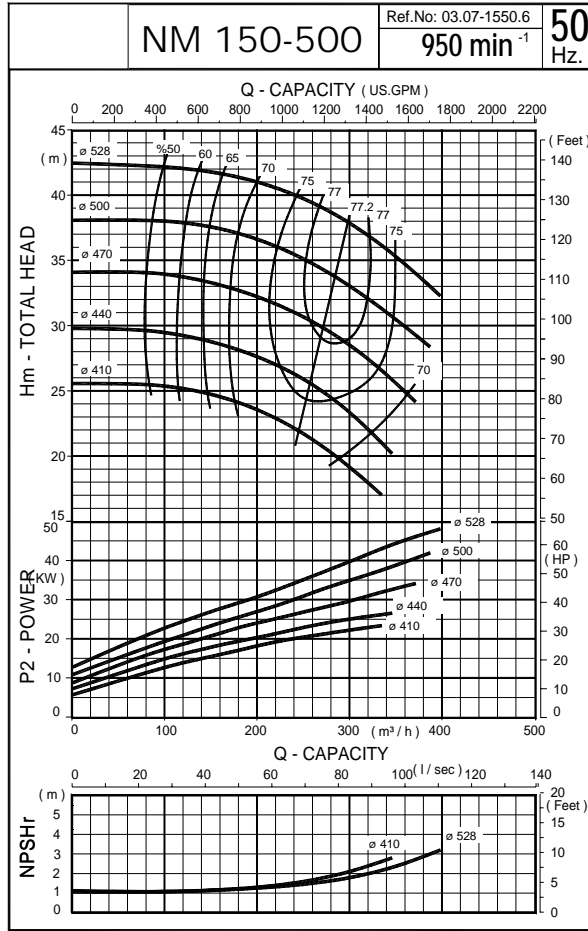

The Performance Curves 50 Hz are based on the kinematic viscosity 1 mm²/s and density 1g/cm³. Tolerances are acc. to ISO 9906 Annex A.

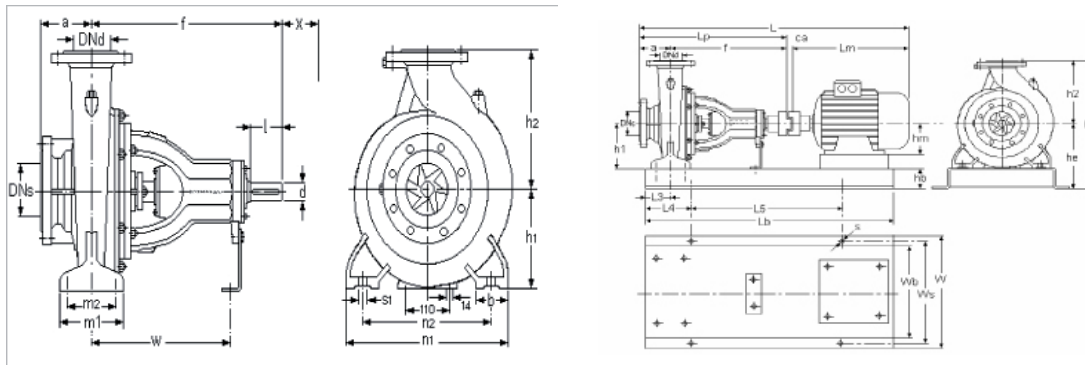

Pump size	Flanges		Length		Height		Mounting details							Shaft end		(*) X mm	Weight kg
	DNs mm	DNd mm	a mm	f mm	h1 mm	h2 mm	b mm	m1 mm	m2 mm	n1 mm	n2 mm	s1 mm	W mm	d mm	l mm		
150-500	200	150	180	700	400	525	110	250	200	620	500	M20	500	55	110	140	197

	MOTOR			PUMP			GENERAL			BASEPLATE									
	KW	IEC	Lm mm	Hm mm	Lp mm	Ca mm	L mm	W mm	H mm	Lb mm	Wb mm	Hb mm	He mm	L3 mm	L4 mm	L5 mm	Ws mm	S mm	Plate No
150-500 6 poles 50 Hz	22	200L	747	200	930	43	1719	830	1045	1600	680	120	520	135	270	1060	760	33	11.09
	30	225M	820	225	930	43	1792	830	1045	1600	680	120	520	135	270	1060	760	33	11.09
	37	250M	890	250	930	43	1863	830	1045	1800	680	120	520	135	300	1200	760	33	11.1
	45	280S	958	280	930	42	1931	830	1045	1800	680	120	520	135	300	1200	760	33	11.1
	55	280M	1010	280	930	42	1983	830	1045	1800	680	120	520	135	300	1200	760	33	11.1
150-500 4 poles 50 Hz	75	280S	958	280	930	43	1881	830	1045	1800	680	120	520	135	300	1200	760	33	11.1
	90	280M	1010	280	930	43	1933	830	1045	1800	680	120	520	135	300	1200	760	33	11.1
	110	315S	1108	315	930	43	2031	830	1045	1800	680	120	520	135	300	1200	760	33	11.1
	132	315M	1160	315	930	43	2083	830	1045	1800	680	120	520	135	300	1200	760	33	11.1
	160	315M	1160	315	930	43	2083	830	1045	1800	680	120	520	135	300	1200	760	33	11.1

NM End Suction Centrifugal Pumps

Performance Curves 50 Hz

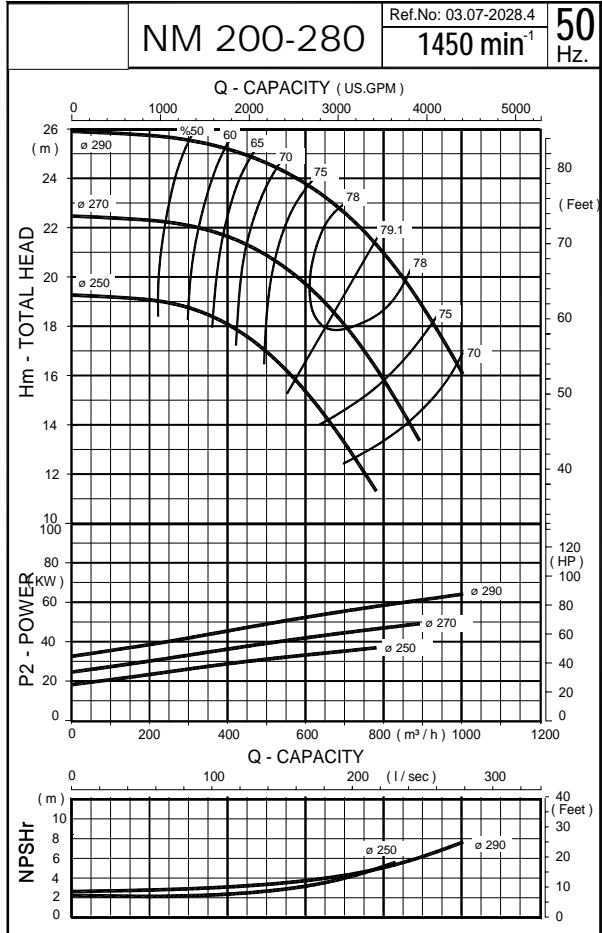
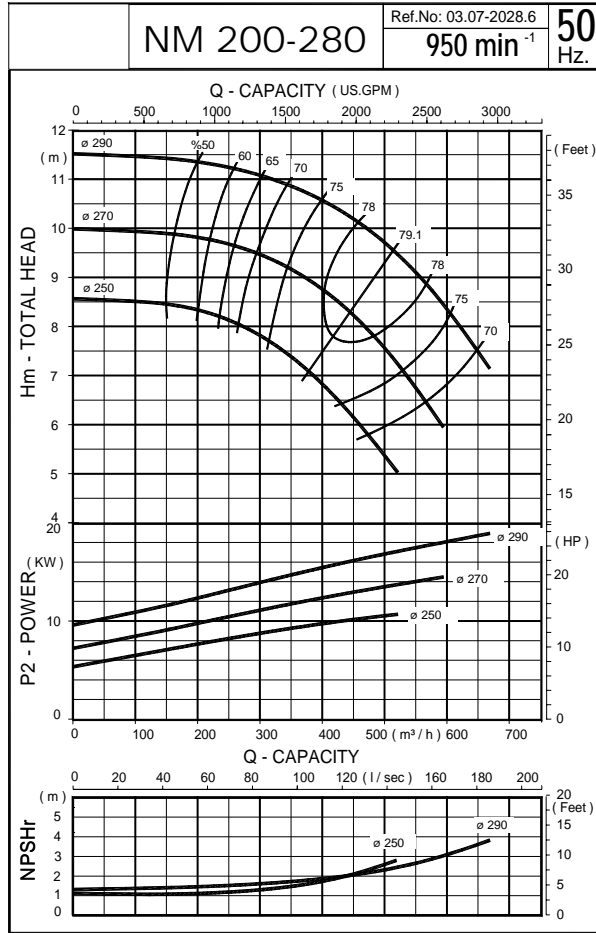

The Performance Curves 50 Hz are based on the kinematic viscosity 1 mm²/s and density 1g/cm³. Tolerances are acc. to ISO 9906 Annex A.

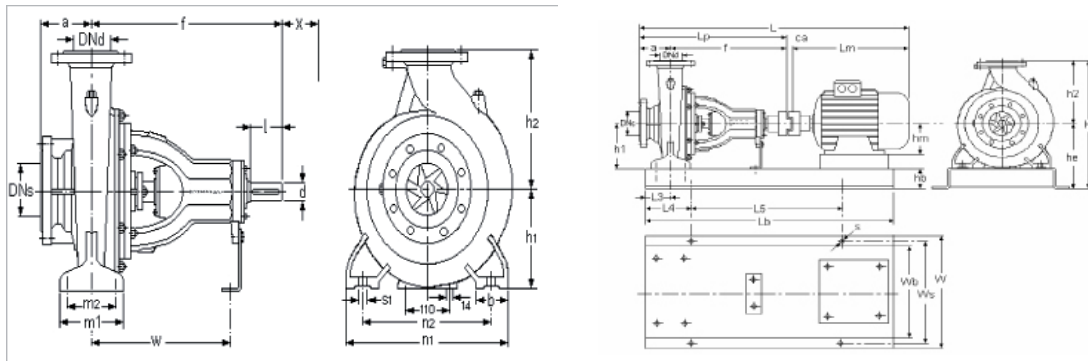

Pump size	Flanges		Length		Height		Mounting details							Shaft end		(*) X mm	Weight kg
	DNs mm	DNd mm	a mm	f mm	h1 mm	h2 mm	b mm	m1 mm	m2 mm	n1 mm	n2 mm	s1 mm	W mm	d mm	l mm		
200-280	250	200	200	560	355	450	110	250	200	620	500	M20	410	42	110	200	300

	MOTOR				PUMP		GENERAL			BASEPLATE									
	KW	IEC	Lm mm	Hm mm	Lp mm	Ca mm	L mm	W mm	H mm	Lb mm	Wb mm	Hb mm	He mm	L3 mm	L4 mm	L5 mm	Ws mm	S mm	Plate No
200-280 6 poles 50 Hz	11	160L	638	160	760	33	1431	830	925	1250	680	120	475	135	205	840	760	33	11.07
	15	180L	692	180	760	33	1485	830	925	1400	680	120	475	135	230	940	760	33	11.08
	18,5	200L	747	200	760	42	1549	830	925	1400	680	120	475	135	230	940	760	33	11.08
200-280 4 poles 50 Hz	37	225S	795	225	760	43	1598	730	925	1400	680	120	475	135	230	940	760	33	11.08
	45	225M	820	225	760	43	1623	830	925	1400	680	120	475	135	230	940	760	33	11.08
	55	250M	890	250	760	43	1693	830	925	1600	680	120	475	135	270	1060	760	33	11.09
	75	280S	958	280	760	43	1761	830	925	1600	680	120	475	135	270	1060	760	33	11.09

NM End Suction Centrifugal Pumps

Performance Curves 50 Hz

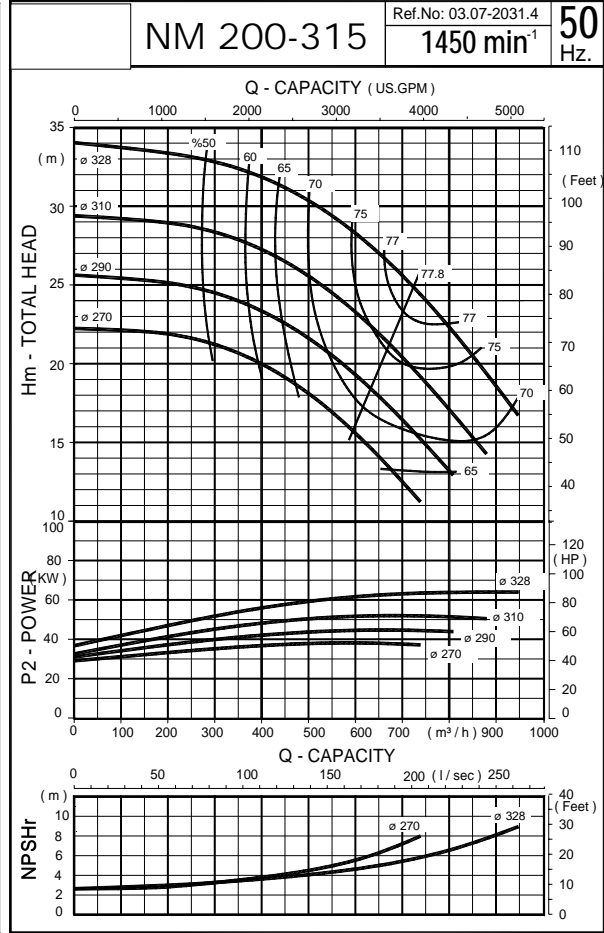
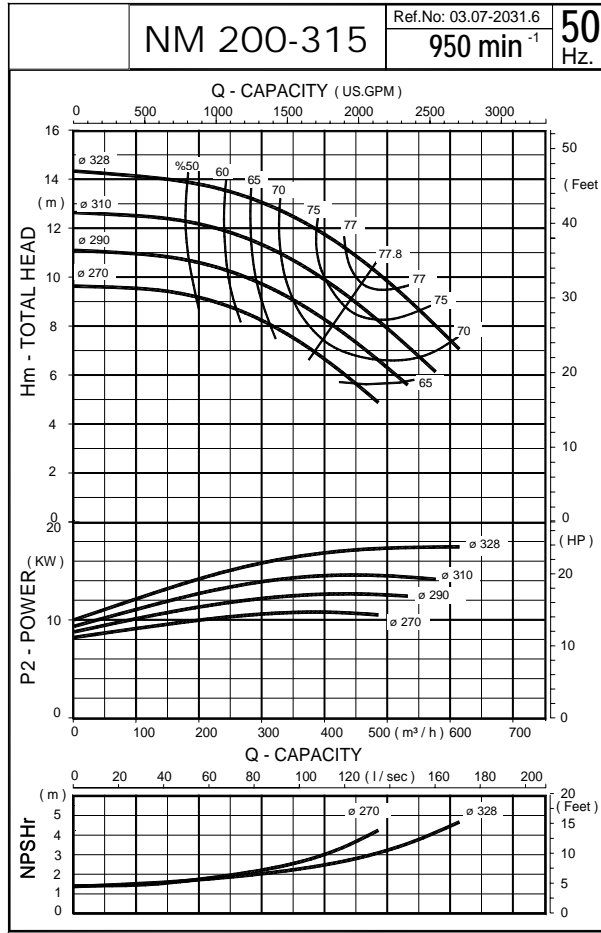

The Performance Curves 50 Hz are based on the kinematic viscosity 1 mm²/s and density 1g/cm³. Tolerances are acc. to ISO 9906 Annex A.

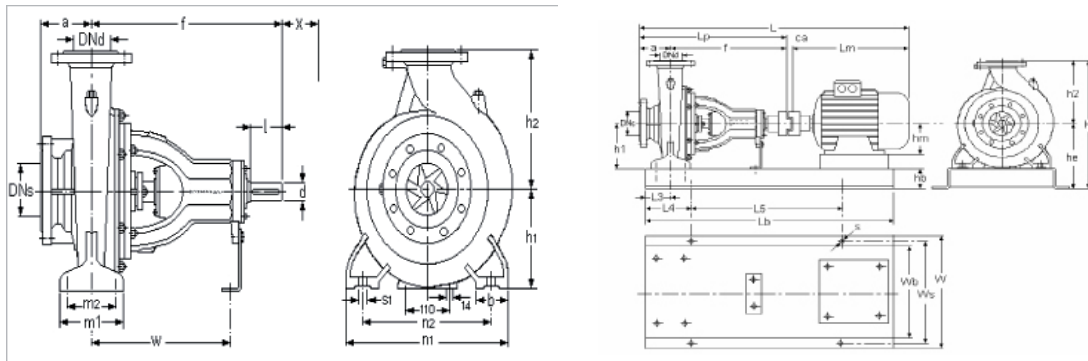

Pump size	Flanges		Length		Height		Mounting details							Shaft end		(*) X mm	Weight kg
	DNs mm	DNd mm	a mm	f mm	h1 mm	h2 mm	b mm	m1 mm	m2 mm	n1 mm	n2 mm	s1 mm	W mm	d mm	l mm		
200-315	250	200	180	535	355	450	110	250	200	620	500	M20	410	42	110	160	201

	MOTOR			PUMP		GENERAL			BASEPLATE										
	KW	IEC	Lm mm	Hm mm	Lp mm	Ca mm	L mm	W mm	H mm	Lb mm	Wb mm	Hb mm	He mm	L3 mm	L4 mm	L5 mm	Ws mm	S mm	Plate No
200-315 6 poles 50 Hz	11	160L	638	160	715	33	1386	830	925	1250	680	120	475	135	205	840	760	33	11.09
	15	180L	692	180	715	33	1440	830	925	1250	680	120	475	135	205	840	760	33	11.07
	18,5	200L	747	200	715	42	1504	830	925	1400	680	120	475	135	230	940	760	33	11.08
200-315 4 poles 50 Hz	37	225S	795	225	715	43	1673	830	925	1600	680	120	475	135	270	1060	760	33	11,09
	45	225M	820	225	715	43	1698	830	925	1600	680	120	475	135	270	1060	760	33	11,09
	55	250M	890	250	715	43	1768	830	925	1600	680	120	475	135	270	1060	760	33	11,09
	75	280S	958	280	715	43	1836	830	925	1600	680	120	475	135	270	1060	760	33	11,09

NM End Suction Centrifugal Pumps

Performance Curves 50 Hz

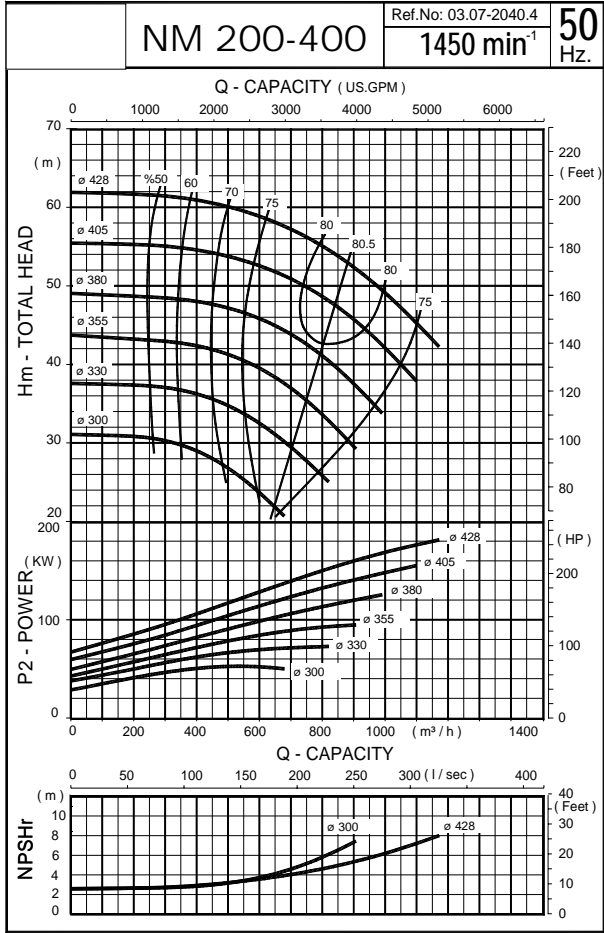
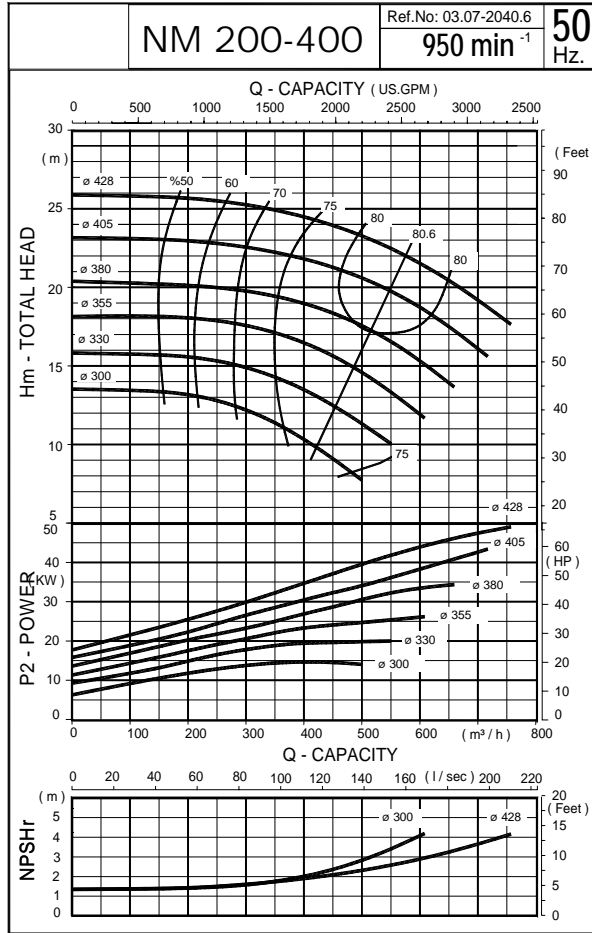

The Performance Curves 50 Hz are based on the kinematic viscosity 1 mm²/s and density 1g/cm³. Tolerances are acc. to ISO 9906 Annex A.

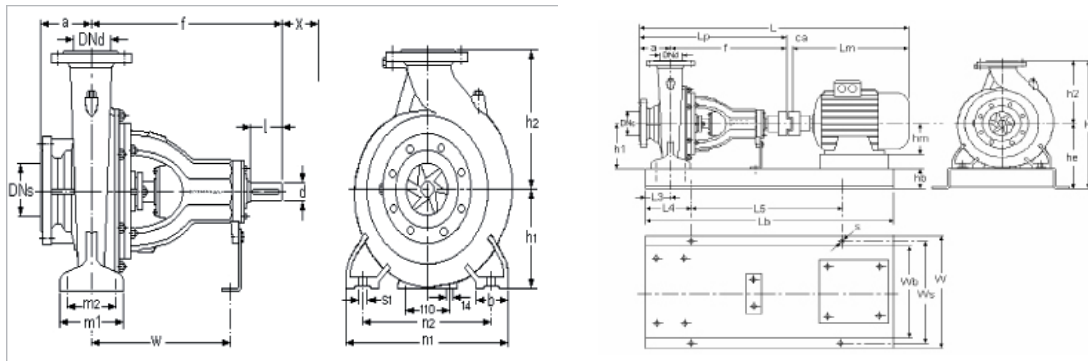

Pump size	Flanges		Length		Height		Mounting details							Shaft end		(*) X mm	Weight kg
	DNs mm	DNd mm	a mm	f mm	h1 mm	h2 mm	b mm	m1 mm	m2 mm	n1 mm	n2 mm	s1 mm	W mm	d mm	l mm		
200-400	250	200	180	710	400	500	110	250	200	620	500	M20	500	55	110	160	354

	MOTOR			PUMP			GENERAL			BASEPLATE									
	KW	IEC	Lm mm	Hm mm	Lp mm	Ca mm	L mm	W mm	H mm	Lb mm	Wb mm	Hb mm	He mm	L3 mm	L4 mm	L5 mm	Ws mm	S mm	Plate No
200-400 6 poles 50 Hz	22	200L	747	200	890	42	1679	830	1020	1600	680	120	520	135	270	1060	760	33	11.09
	30	225M	820	225	890	42	1752	830	1020	1600	680	120	520	135	270	1060	760	33	11.09
	37	250M	890	250	890	43	1823	830	1020	1600	680	120	520	135	270	1060	760	33	11.09
	45	280S	958	280	890	43	1891	830	1020	1800	680	120	520	135	300	1200	760	33	11.1
	55	280M	1010	280	890	43	1943	830	1020	1800	680	120	520	135	300	1200	760	33	11.1
200-400 4 poles 50 Hz	55	250M	890	250	890	43	1823	830	1020	1600	680	120	520	135	270	1060	760	33	11.09
	75	280S	958	280	890	43	1891	830	1020	1800	680	120	520	135	300	1200	760	33	11.1
	90	280M	1010	280	890	43	1943	830	1020	1800	680	120	520	135	300	1200	760	33	11.1
	110	315S	1108	315	890	43	2041	830	1020	1800	680	120	520	135	300	1200	760	33	11.1
	132	315M	1160	315	890	43	2093	830	1020	1800	680	120	520	135	300	1200	760	33	11.1
	160	315M	1160	315	890	43	2093	830	1020	1800	680	120	520	135	300	1200	760	33	11.1
	185	315L	1250	315	890	43	2183	830	1020	2000	680	120	520	135	340	1320	760	33	11.11

NM End Suction Centrifugal Pumps

Performance Curves 50 Hz

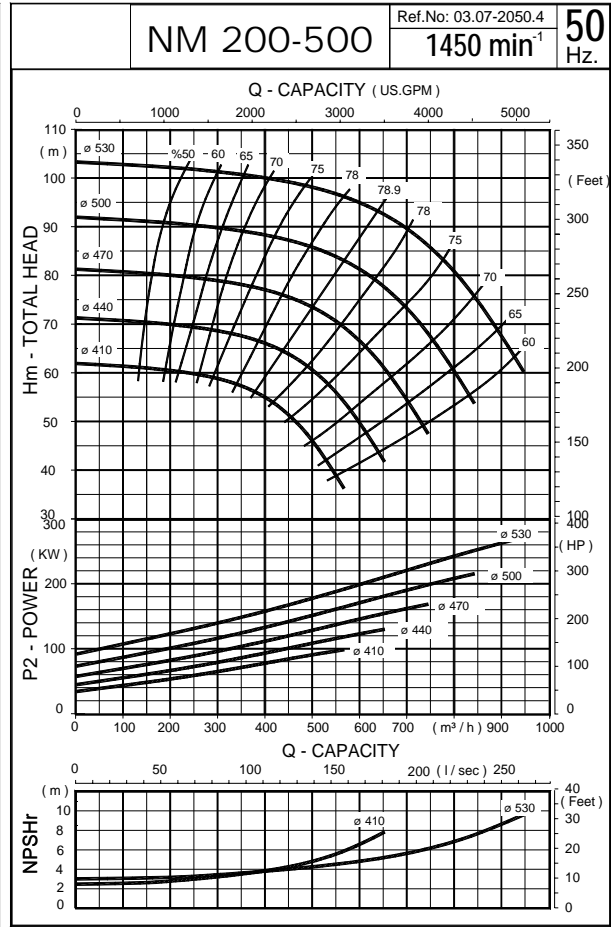
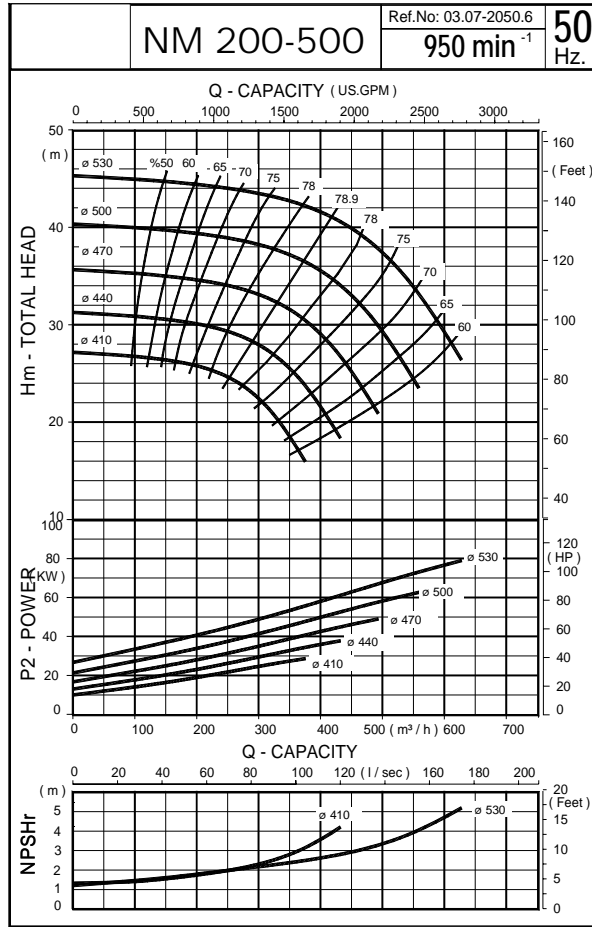

The Performance Curves 50 Hz are based on the kinematic viscosity 1 mm²/s and density 1g/cm³. Tolerances are acc. to ISO 9906 Annex A.

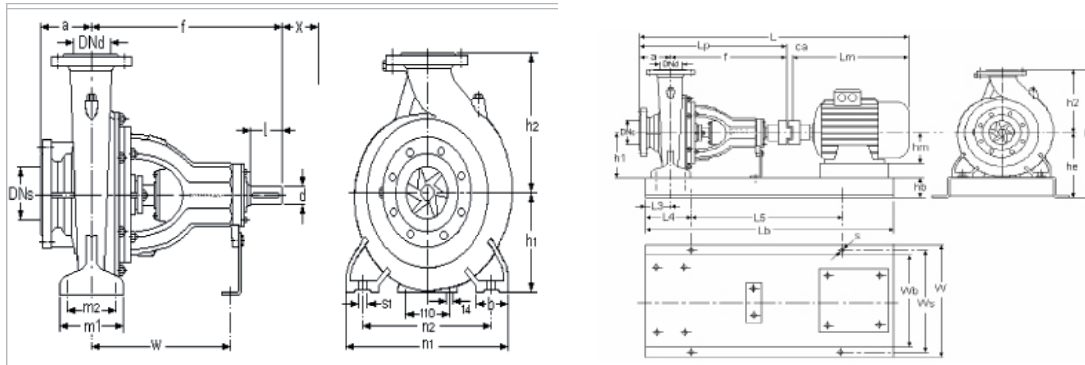

Pump size	Flanges		Length		Height		Mounting details						Shaft end		(*) X mm	Weight kg	
	DNs mm	DNd mm	a mm	f mm	h1 mm	h2 mm	b mm	m1 mm	m2 mm	n1 mm	n2 mm	s1 mm	W mm	d mm			l mm
200-500	300	250	280	875	500	700	150	360	290	900	750	M28	560	65	140	320	615

	MOTOR				PUMP		GENERAL				BASEPLATE									
	KW	IEC	Lm mm	Hm mm	Lp mm	Ca mm	L mm	W mm	H mm	Lb mm	Wb mm	Hb mm	He mm	L3 mm	L4 mm	L5 mm	Ws mm	S mm	Plate No	
200-500 6 poles 50Hz	30	225M	820	225	1060	42	1922	915	1050	1800	750	150	550	160	300	1200	840	33	12,1	
	37	250M	890	250	1060	43	1993	915	1050	1800	750	150	550	160	300	1200	840	33	12,1	
	45	280M	958	280	1060	43	2061	915	1050	2000	750	150	550	160	340	1320	840	33	12,11	
	55	280M	1010	280	1060	43	2113	915	1050	2000	750	150	550	160	340	1320	840	33	12,11	
	75	315S	1108	315	1060	43	2211	915	1050	2000	750	150	550	160	340	1320	840	33	12,11	
200-500 4 poles 50Hz	90	315M	1160	315	1060	43	2263	915	1050	2000	750	150	550	160	340	1320	840	33	12,11	
	110	315S	1108	315	1060	43	2211	915	1050	2000	750	150	550	160	340	1320	840	33	12,11	
	132	315M	1160	315	1060	43	2263	915	1050	2000	750	150	550	160	340	1320	840	33	12,11	
	160	315M	1160	315	1060	43	2263	915	1050	2000	750	150	550	160	340	1320	840	33	12,11	
	185	315L	1250	315	1060	43	2353	915	1100	2250	750	150	550	160	390	1470	840	33	12,12	
	200	315L	1250	315	1060	43	2353	915	1100	2250	750	150	550	160	390	1470	840	33	12,12	
	250	355M	1370	315	1060	43	2473	915	1100	2250	750	150	550	160	390	1470	840	33	12,12	

NM End Suction Centrifugal Pumps

Performance Curves 50 Hz

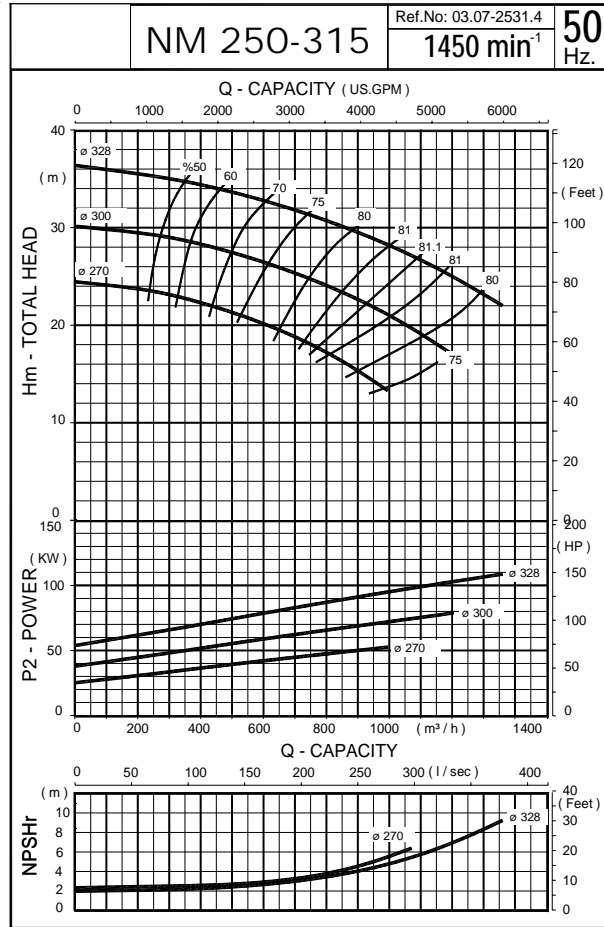
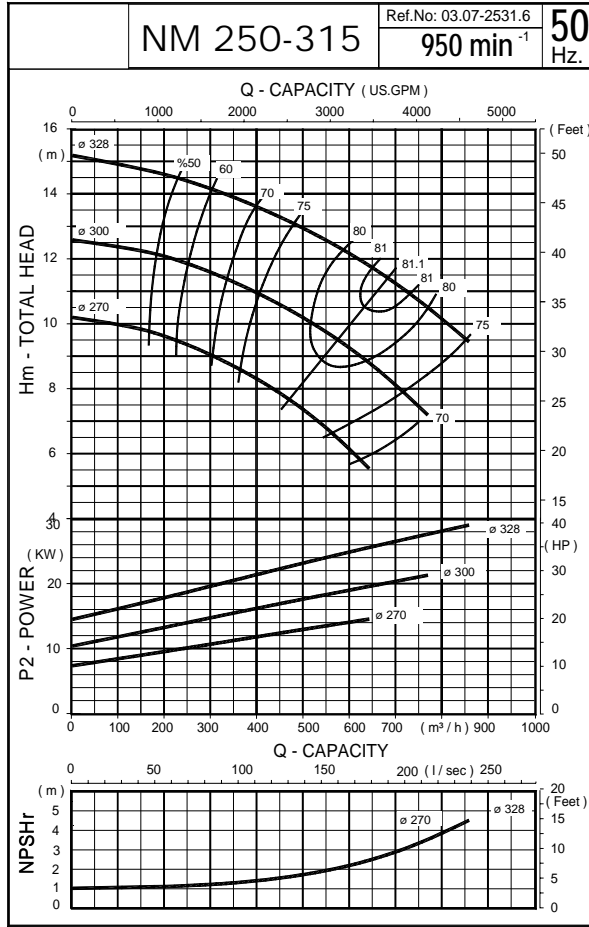

The Performance Curves 50 Hz are based on the kinematic viscosity 1 mm²/s and density 1g/cm³. Tolerances are acc. to ISO 9906 Annex A.

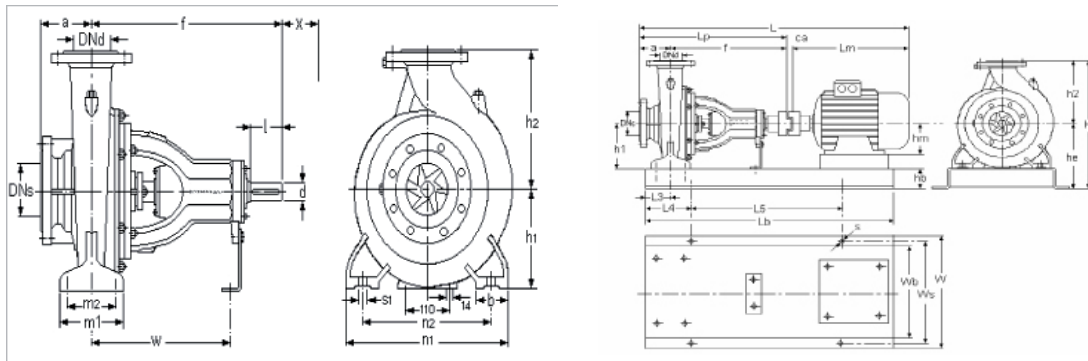

Pump size	Flanges		Length		Height		Mounting details							Shaft end		(*) X mm	Weight kg
	DNs mm	DNd mm	a mm	f mm	h1 mm	h2 mm	b mm	m1 mm	m2 mm	n1 mm	n2 mm	s1 mm	W mm	d mm	l mm		
250-315	300	250	240	725	400	525	140	300	240	620	500	M24	500	55	110	200	419

	MOTOR				PUMP		GENERAL			BASEPLATE									
	KW	IEC	Lm mm	Hm mm	Lp mm	Ca mm	L mm	W mm	H mm	Lb mm	Wb mm	Hb mm	He mm	L3 mm	L4 mm	L5 mm	Ws mm	S mm	Plate No
250-315 6 poles 50 Hz	15	180L	692	180	965	33	1690	830	1045	1600	680	120	520	160	270	1060	760	33	11.09
	18,5	200L	747	200	965	42	1754	830	1045	1600	680	120	520	160	270	1060	760	33	11.09
	22	200L	747	200	965	42	1754	830	1045	1600	680	120	520	160	270	1060	760	33	11.09
	30	225M	820	225	965	42	1827	830	1045	1600	680	120	520	160	270	1060	760	33	11.09
250-315 4 poles 50 Hz	55	250M	890	250	965	43	1898	830	1045	1800	680	120	520	160	300	1200	760	33	11,1
	75	280S	958	280	965	43	1966	830	1045	1800	680	120	520	160	300	1200	760	33	11,1
	90	280M	1010	280	965	43	2018	830	1045	1800	680	120	520	160	300	1200	760	33	11,1
	110	315S	1108	315	965	43	2116	830	1045	1800	680	120	520	160	300	1200	760	33	11,1

NM End Suction Centrifugal Pumps

Performance Curves 50 Hz

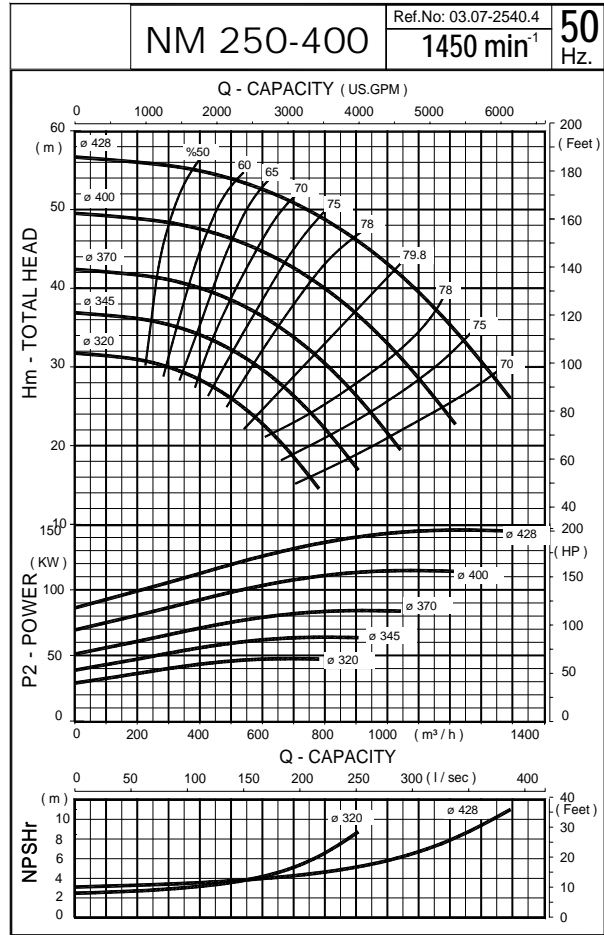
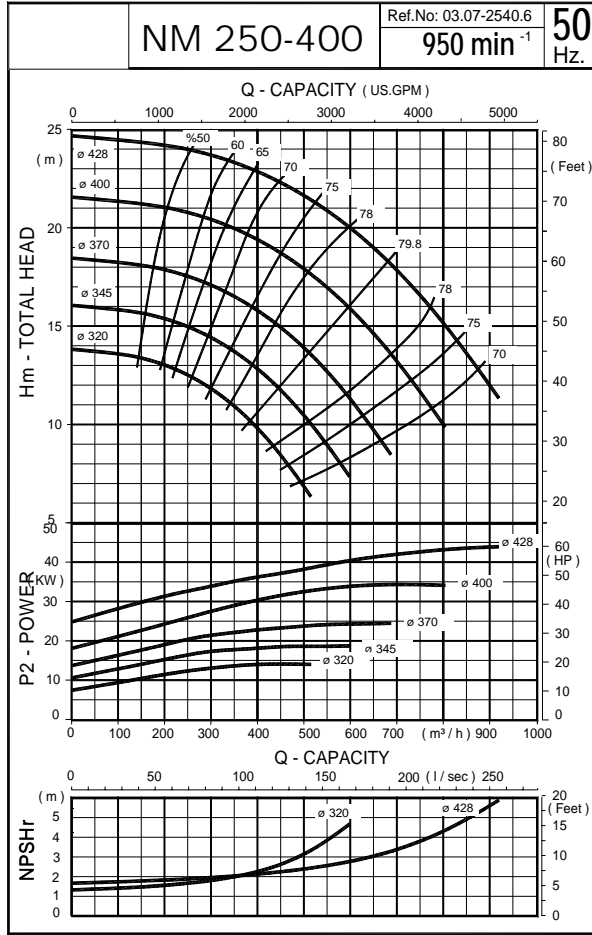

The Performance Curves 50 Hz are based on the kinematic viscosity 1 mm²/s and density 1g/cm³. Tolerances are acc. to ISO 9906 Annex A.

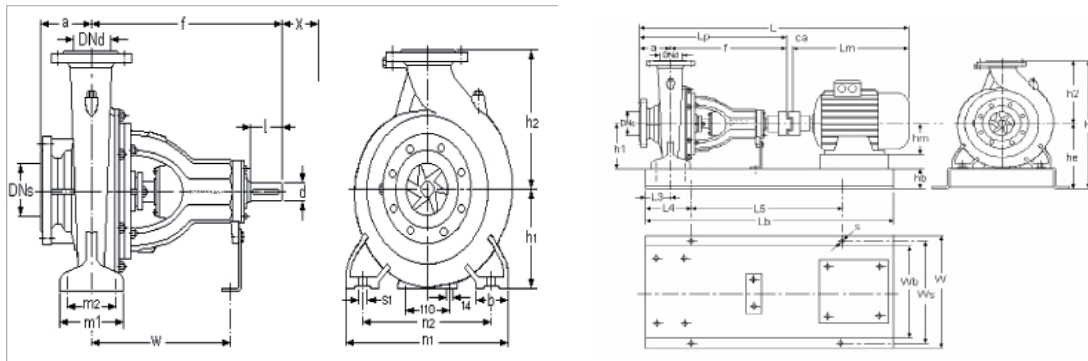

Pump size	Flanges		Length		Height		Mounting details							Shaft end		(*) X mm	Weight kg
	DNs mm	DNd mm	a mm	f mm	h1 mm	h2 mm	b mm	m1 mm	m2 mm	n1 mm	n2 mm	s1 mm	W mm	d mm	l mm		
250-400	300	250	225	865	400	550	140	300	240	620	500	M24	600	65	140	200	510

	MOTOR			PUMP			GENERAL			BASEPLATE									
	KW	IEC	Lm mm	Hm mm	Lp mm	Ca mm	L mm	W mm	H mm	Lb mm	Wb mm	Hb mm	He mm	L3 mm	L4 mm	L5 mm	Ws mm	S mm	Plate No
250-400 6 poles 50 Hz	22	200L	747	200	1090	42	1879	830	1070	1800	680	120	520	160	300	1200	760	33	11,1
	30	225M	820	225	1090	42	1952	830	1070	1800	680	120	520	160	300	1200	760	33	11,1
	37	250M	890	250	1090	43	2023	830	1070	1800	680	120	520	160	300	1200	760	33	11,1
	45	280S	958	280	1090	43	2091	830	1070	2000	680	120	520	160	340	1320	760	33	11,11
	55	280M	1010	280	1090	43	2143	830	1070	2000	680	120	520	160	340	1320	760	33	11,11
	75	315M	1108	315	1090	43	2241	830	1070	2000	680	120	520	160	340	1320	760	33	11,11
250-400 4 poles 50 Hz	75	280S	958	250	1090	43	2091	830	1070	2000	680	120	520	160	340	1320	760	33	11,11
	90	280M	1010	280	1090	43	2143	830	1070	2000	680	120	520	160	340	1320	760	33	11,11
	110	315S	1108	315	1090	43	2241	830	1070	2000	680	120	520	160	340	1320	760	33	11,11
	132	315M	1160	315	1090	43	2293	830	1070	2000	680	120	520	160	340	1320	760	33	11,11
	160	315M	1160	315	1090	43	2293	830	1070	2000	680	120	520	160	340	1320	760	33	11,11
	185	315L	1250	315	1090	43	2383	830	1070	2250	680	120	520	160	390	1470	760	33	11,12
	200	315L	1250	315	1090	43	2383	830	1070	2250	680	120	520	160	390	1470	760	33	11,12

NM End Suction Centrifugal Pumps

Performance Curves 50 Hz

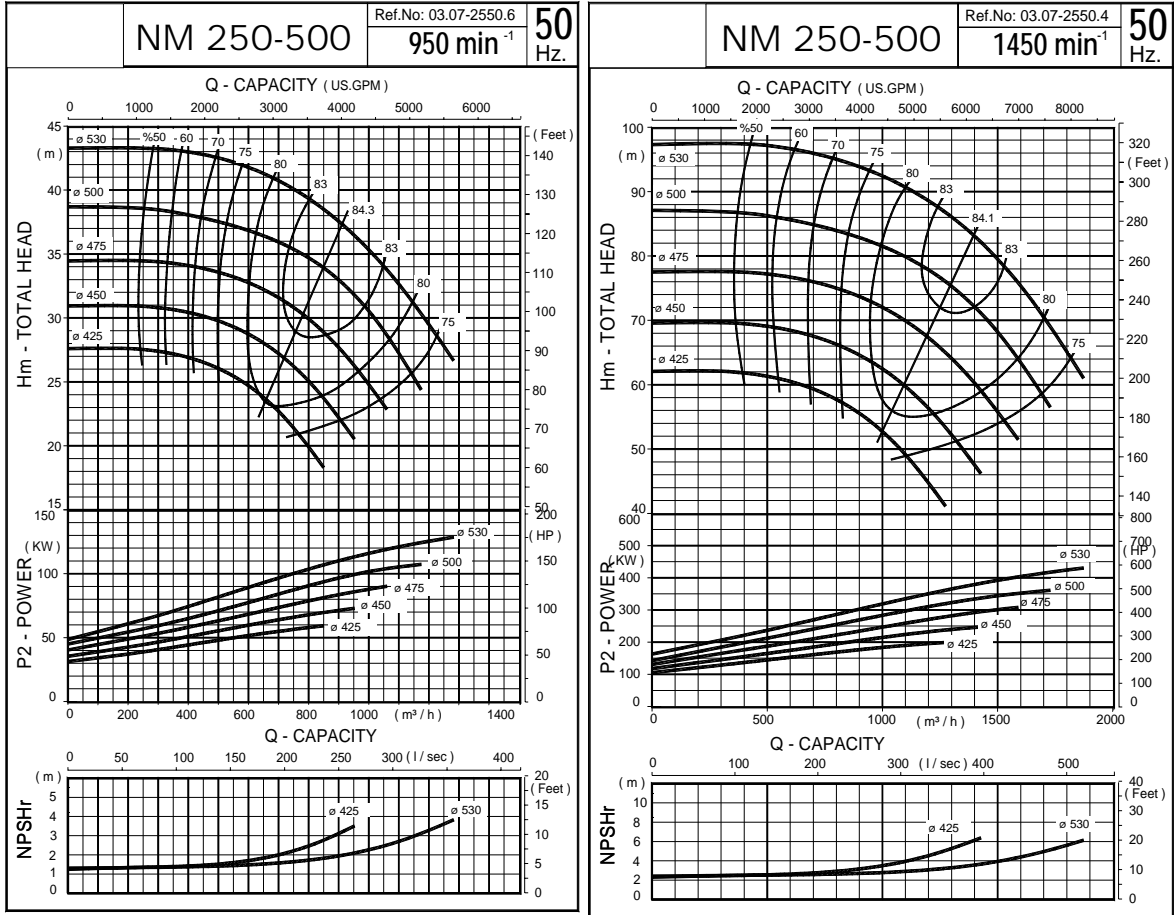

The Performance Curves 50 Hz are based on the kinematic viscosity 1 mm²/s and density 1g/cm³. Tolerances are acc. to ISO 9906 Annex A.

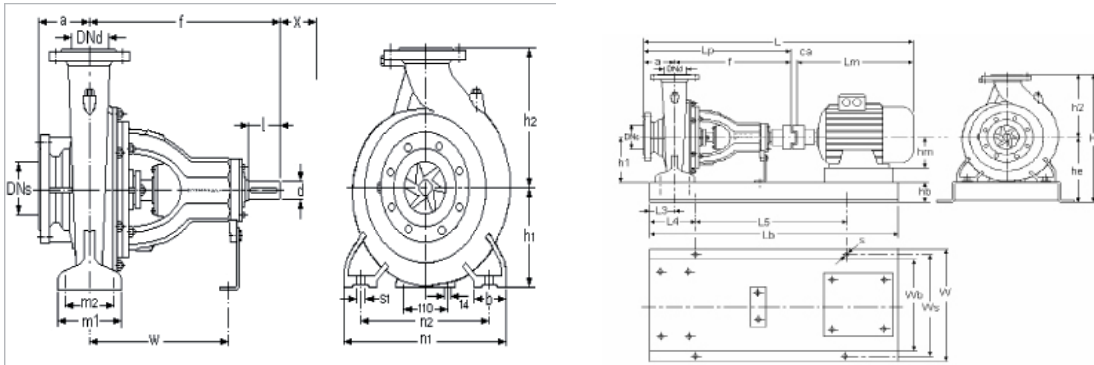

Pump size	Flanges		Length		Height		Mounting details							Shaft end		(*) X mm	Weight kg
	DNs mm	DNd mm	a mm	f mm	h1 mm	h2 mm	b mm	m1 mm	m2 mm	n1 mm	n2 mm	s1 mm	W mm	d mm	l mm		
250-500	300	250	280	875	500	700	150	360	290	900	750	M28	560	65	140	320	615

	MOTOR			PUMP		GENERAL			BASEPLATE										
	KW	IEC	Lm mm	Hm mm	Lp mm	Ca mm	L mm	W mm	H mm	Lb mm	Wb mm	Hb mm	He mm	L3 mm	L4 mm	L5 mm	Ws mm	S mm	Plate No
250-500 4 poles 50 Hz	45	280S	958	280	1090	43	2091	915	1230	2000	750	150	600	160	340	1320	840	33	12.11
	55	280M	1010	280	1090	43	2143	915	1230	2000	750	150	600	160	340	1320	840	33	12.11
	75	315S	1108	315	1090	43	2241	915	1230	2000	750	150	600	160	340	1320	840	33	12.11
	90	315M	1160	315	1090	43	2293	915	1230	2000	750	150	600	160	340	1320	840	33	12.11
	110	315M	1160	315	1090	43	2293	915	1230	2000	750	150	600	160	340	1320	840	33	12.11
	132	315L	1250	315	1090	43	2293	915	1230	2250	750	150	600	160	390	1470	840	33	12.12
250-500 4 poles 50 Hz	160	315M	1160	315	1090	43	2358	1100	1350	2250	900	150	650	190	390	1470	1000	33	13.12
	185	315L	1250	315	1090	43	2448	1100	1350	2250	900	150	650	190	390	1470	1000	33	13.12
	200	315L	1250	315	1090	43	2448	1100	1350	2250	900	150	650	190	390	1470	1000	33	13.12
	250	355M	1370	355	1090	43	2568	1100	1350	2250	900	150	650	190	390	1470	1000	33	13.12
	315	355M	1370	355	1090	43	2568	1100	1350	2250	900	150	650	190	390	1470	1000	33	13.12
	355	355M	1370	355	1090	43	2568	1100	1350	2250	900	150	650	190	390	1470	1000	33	13.12
	400	355L	1440	355	1090	43	2638	1100	1350	2500	900	150	650	190	440	1620	1000	33	13.13

NM End Suction Centrifugal Pumps

Performance Curves 50 Hz

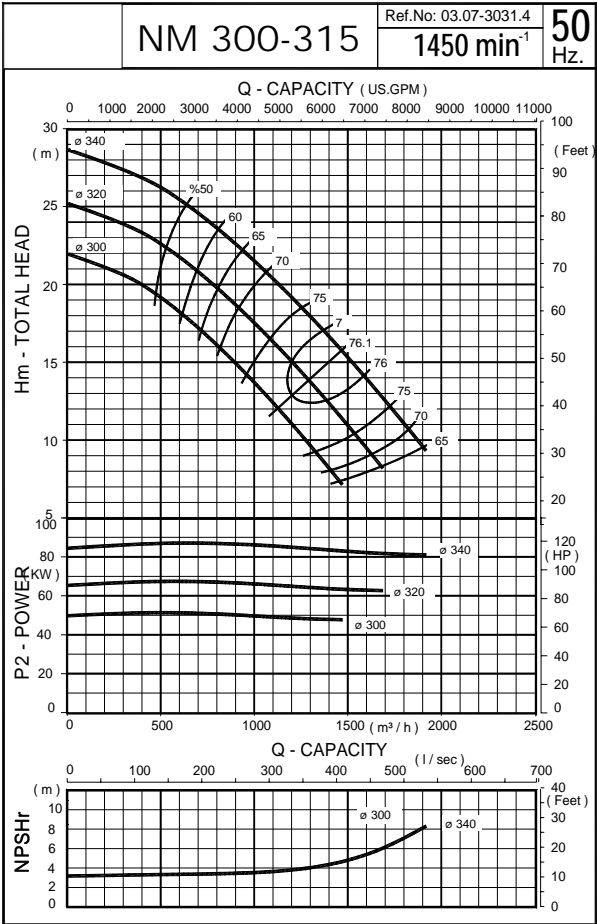
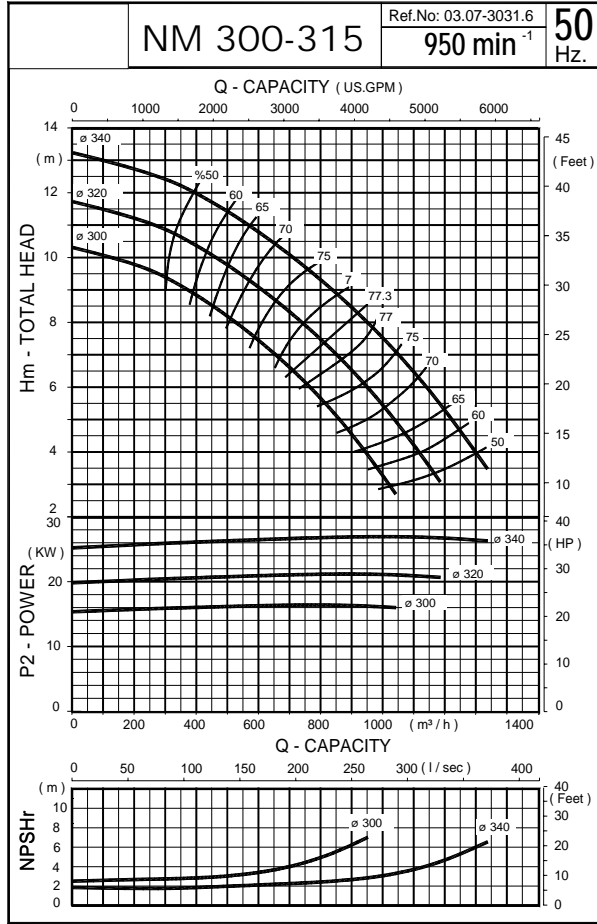

The Performance Curves 50 Hz are based on the kinematic viscosity 1 mm²/s and density 1g/cm³. Tolerances are acc. to ISO 9906 Annex A.

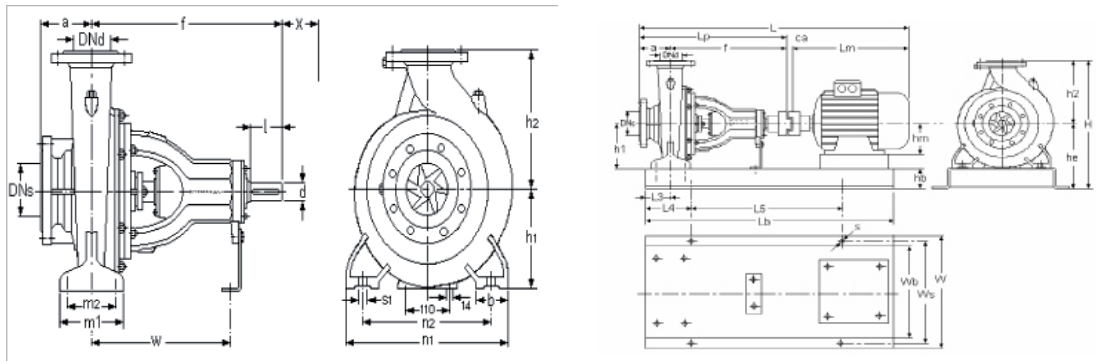

Pump size	Flanges		Length		Height		Mounting details						Shaft end		(*) X mm	Weight kg	
	DNs mm	DNd mm	a mm	f mm	h1 mm	h2 mm	b mm	m1 mm	m2 mm	n1 mm	n2 mm	s1 mm	W mm	d mm			l mm
300-315	300	300	275	810	425	600	140	300	240	620	500	M24	550	55	140	270	516

	MOTOR			PUMP		GENERAL			BASEPLATE										
	KW	IEC	Lm mm	Hm mm	Lp mm	Ca mm	L mm	W mm	H mm	Lb mm	Wb mm	Hb mm	He mm	L3 mm	L4 mm	L5 mm	Ws mm	S mm	Plate No
300-315 6 poles 50 Hz	18.5	200L	747	200	1085	42	1874	830	1145	1600	680	120	545	160	270	1060	760	33	11.09
	22	200L	747	200	1085	42	1874	830	1145	1600	680	120	545	160	270	1060	760	33	11.09
	30	225M	820	225	1085	42	1947	830	1145	1800	680	120	545	160	300	1200	760	33	11.1
	37	250M	820	250	1085	43	2018	830	1145	1800	680	120	545	160	300	1200	760	33	11.1
300-315 4 poles 50 Hz	75	280S	958	280	1085	43	2116	830	1145	1800	680	120	545	160	300	1200	760	33	11,1
	90	280M	1010	280	1085	43	2168	830	1145	2000	680	120	545	160	340	1320	760	33	11,11
	110	315S	1108	315	1085	43	2266	830	1145	2000	680	120	545	160	340	1320	760	33	11,11
	132	315M	1160	315	1085	43	2318	830	1145	2000	680	120	545	160	340	1320	760	33	11,11

NM End Suction Centrifugal Pumps

Performance Curves 50 Hz

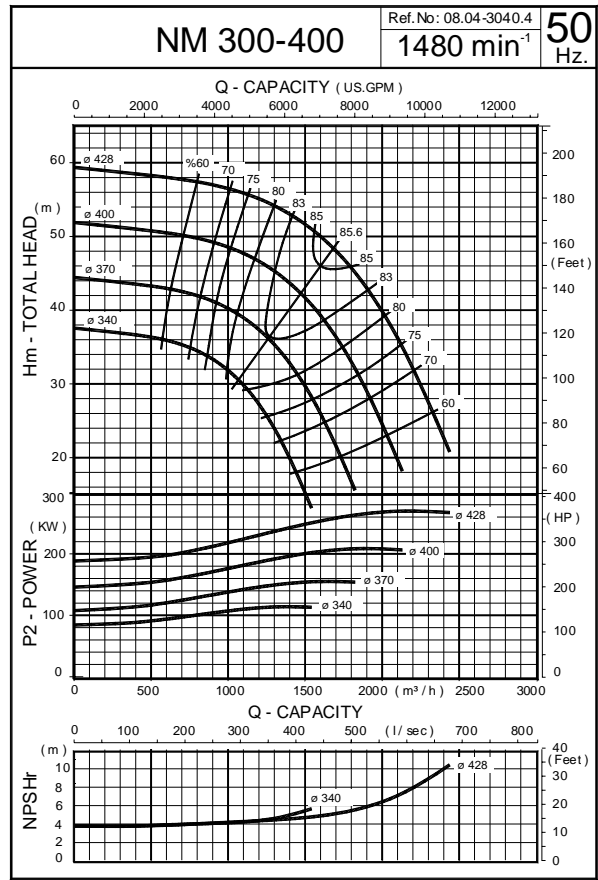
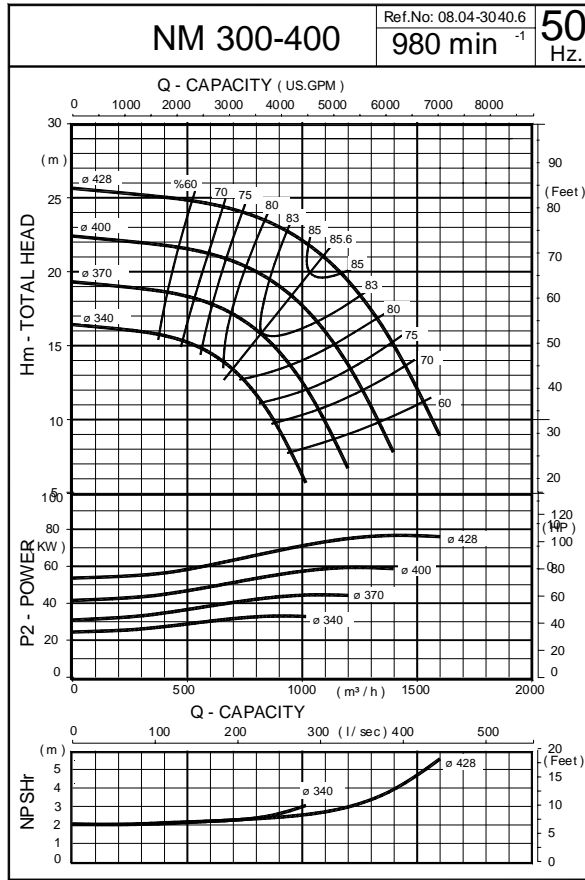

The Performance Curves 50 Hz are based on the kinematic viscosity 1 mm²/s and density 1g/cm³. Tolerances are acc. to ISO 9906 Annex A.

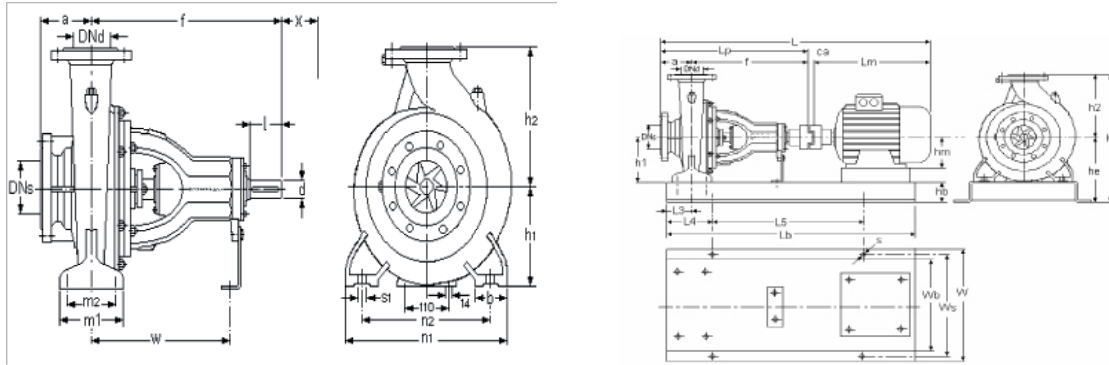

Pump size	Flanges		Length		Height		Mounting details							Shaft end		(*) X mm	Weight kg
	DNs mm	DNd mm	a mm	f mm	h1 mm	h2 mm	b mm	m1 mm	m2 mm	n1 mm	n2 mm	s1 mm	W mm	d mm	l mm		
300-400	350	300	275	865	450	630	150	360	290	800	650	24	550	65	140	300	

	MOTOR				PUMP		GENERAL			BASEPLATE									
	KW	IEC	Lm mm	Hm mm	Lp mm	Ca mm	L mm	W mm	H mm	Lb mm	Wb mm	Hb mm	He mm	L3 mm	L4 mm	L5 mm	Ws mm	S mm	Plate No
300-400 6 poles 50 Hz	160	315M	1160	315	1140	43	2343	1100	1230	2000	900	150	600	190	340	1320	1000	33	13,11
	185	315L	1250	315	1140	43	2433	1100	1230	2250	900	150	600	190	390	1470	1000	33	13,12
	200	315L	1250	315	1140	43	2433	1100	1230	2250	900	150	600	190	390	1470	1000	33	13,12
	250	355M	1370	355	1140	43	2553	1100	1230	2250	900	150	600	190	390	1470	1000	33	13,12
300-400 4 poles 50 Hz	45	280M	958	280	1140	43	2141	1100	1230	2000	900	150	600	190	340	1320	1000	33	13,11
	55	280M	1010	280	1140	43	2193	1100	1230	2000	900	150	600	190	340	1320	1000	33	13,11
	75	315S	1108	315	1140	43	2291	1100	1230	2000	900	150	600	190	340	1320	1000	33	13,11
	90	315M	1160	315	1140	43	2343	1100	1230	2000	900	150	600	190	340	1320	1000	33	13,11

NM End Suction Centrifugal Pumps

Performance Curves 50 Hz

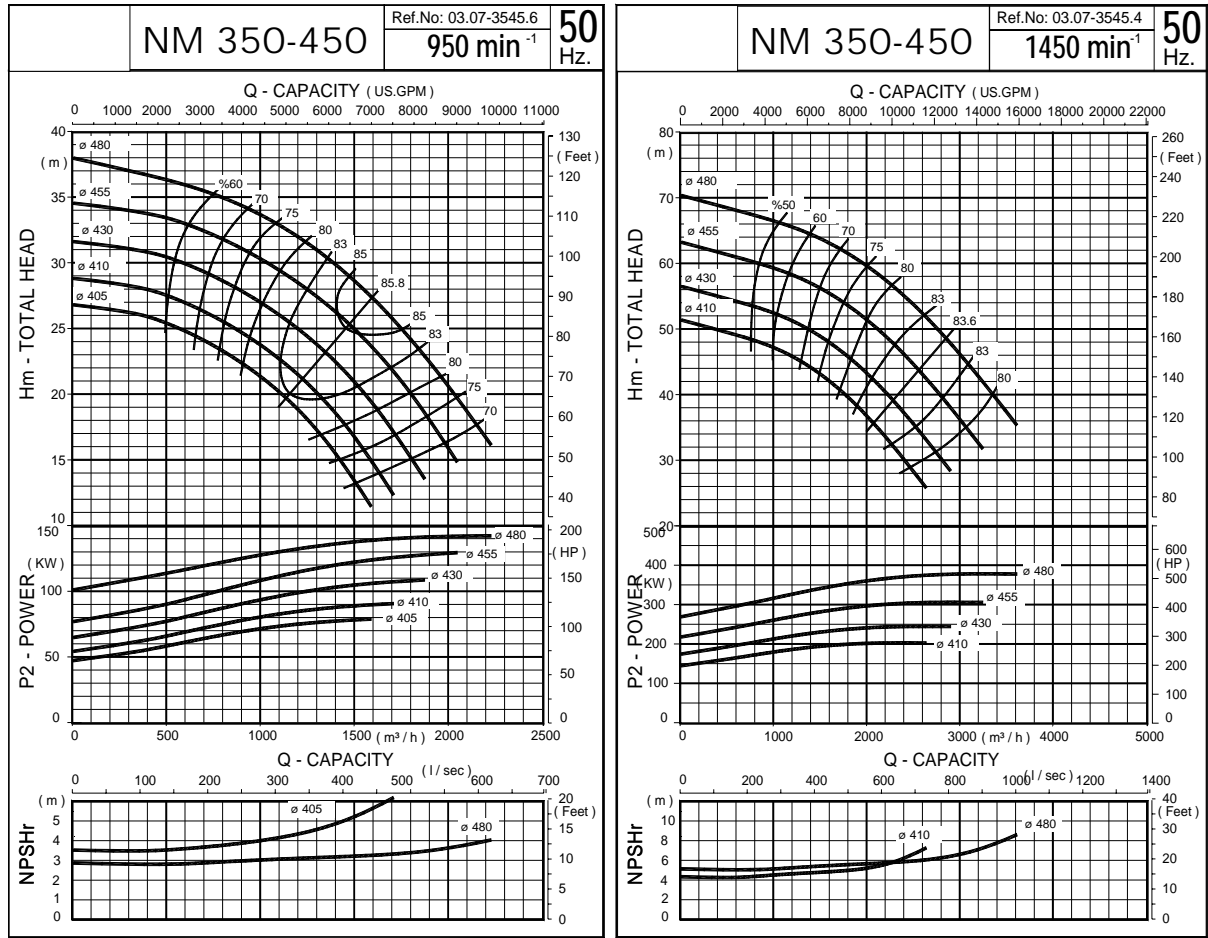

The Performance Curves 50 Hz are based on the kinematic viscosity 1 mm²/s and density 1g/cm³. Tolerances are acc. to ISO 9906 Annex A.

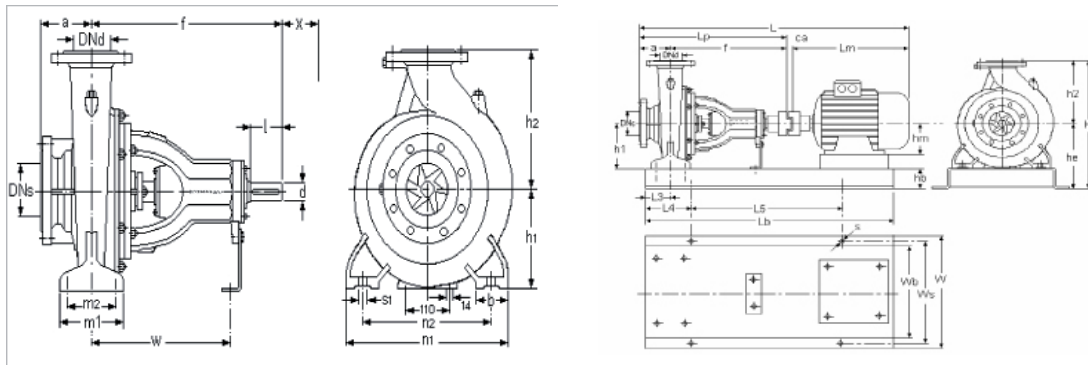

Pump size	Flanges		Length		Height		Mounting details							Shaft end		(*) X mm	Weight kg
	DN _s mm	DN _d mm	a mm	f mm	h1 mm	h2 mm	b mm	m1 mm	m2 mm	n1 mm	n2 mm	s1 mm	W mm	d mm	l mm		
350-450	400	350	280	875	500	700	150	360	290	900	750	M24	560	65	140	300	755

	MOTOR			PUMP			GENERAL			BASEPLATE									
	KW	IEC	L _m mm	H _m mm	L _p mm	Ca mm	L mm	W mm	H mm	L _b mm	W _b mm	H _b mm	He mm	L ₃ mm	L ₄ mm	L ₅ mm	W _s mm	S mm	Plate No
350-450 6 poles 50 Hz	75	315S	1108	315	1155	43	2306	1100	1350	2000	900	150	650	190	340	1320	1000	33	13,11
	90	315M	1160	315	1155	43	2358	1100	1350	2250	900	150	650	190	390	1470	1000	33	13,12
	110	315M	1160	315	1155	43	2358	1100	1350	2250	900	150	650	190	390	1470	1000	33	13,12
	132	315L	1250	315	1155	43	2448	1100	1350	2250	900	150	650	190	390	1470	1000	33	13,12
350-450 4 poles 50 Hz	160	355M	1370	355	1155	43	2568	1100	1350	2250	900	150	650	190	390	1470	1000	33	13,12
	250	355M	1370	355	1155	43	2568	1100	1350	2250	900	150	650	190	390	1470	1000	33	13,12
	315	355M	1370	355	1155	43	2568	1100	1350	2250	900	150	650	190	390	1470	1000	33	13,12
	355	355M	1370	355	1155	43	2568	1100	1350	2250	900	150	650	190	390	1470	1000	33	13,12
	400	355L	1440	355	1155	43	1638	1100	1350	2500	900	150	650	190	440	1620	1000	33	13,13

NM End Suction Centrifugal Pumps

Permissible Loads and Torques on Pump Flanges

Load and torque components on discharge flanges : $F_{xD}, F_{yD}, F_{zD}, M_{xD}, M_{yD}, M_{zD}$
 Load and torque components on suction flanges : $F_{xS}, F_{yS}, F_{zS}, M_{xS}, M_{yS}, M_{zS}$
 Dimension for force and torque : N, Nm

$F_{VD} = |F_{yD}|$: Amount of vertical load on discharge flange
 $F_{VS} = |F_{yS}|$: Amount of vertical load on suction flange
 $F_{HD} = (F_{xD}^2 + F_{zD}^2)^{1/2}$: Amount of horizontal load on discharge flange
 $F_{HS} = (F_{xS}^2 + F_{zS}^2)^{1/2}$: Amount of horizontal load on suction flange
 $M_D = (M_{xD}^2 + M_{yD}^2 + M_{zD}^2)^{1/2}$: Amount of torque on discharge flange
 $M_S = (M_{xS}^2 + M_{yS}^2 + M_{zS}^2)^{1/2}$: Amount of torque on suction flange

$\Sigma F_V = 2/3 \times F_{VD} + F_{VS}$: Sum of vertical loads
 $\Sigma F_H = F_{HD} + F_{HS}$: Sum of horizontal loads
 $\Sigma M = M_D + M_S$: Sum of torques

The load on the flange is permissible if the following condition is fulfilled.

$$(\Sigma F_V / \Sigma F_{Vmax}) + (\Sigma F_H / \Sigma F_{Hmax}) + (\Sigma M / \Sigma M_{max}) \leq 2$$

PUMP TYPE	F_{Vmax} [N]	F_{Hmax} [N]	M_{max} [Nm]
NM 32-160	2450	1850	350
NM 32-200			
NM 32-250			

NM 40-160	2550	1900	400
NM 40-200			
NM 40-250			

NM 50-160	2650	1950	450
NM 50-200			
NM 50-250			
NM 50-315	2900	2200	550

NM 65-160	3000	2150	650
NM 65-200			
NM 65-250			
NM 65-315	3250	2250	750
NM 65-400			

NM 80-160	3600	2450	950
NM 80-200			
NM 80-250			
NM 80-315	3850	2600	1050
NM 80-400			

PUMP TYPE	F_{Vmax} [N]	F_{Hmax} [N]	M_{max} [Nm]
NM 100-250	4750	3000	1400
NM 100-315	4900	3050	1450
NM 100-400			

NM 125-200	7850	4850	2700
NM 125-250	7050	4300	2300
NM 125-315			
NM 125-400			

NM 150-200	9900	6500	3600
NM 150-250			
NM 150-315	9550	6250	3450
NM 150-400			

NM 200-280	13200	9200	4000
NM 200-315			
NM 200-400	12750	8350	4600
NM 200-500			

NM 250-315	16500	11500	5000
NM 250-400	15950	10450	5750
NM 250-500			

NM 300-315	19800	13800	6000
NM 300-400			

NM 350-450	23100	16100	7500
------------	-------	-------	------

Note: Pumps are mounted on base plate pressed of steel-sheet, filled with grout and discharge branch upward. Pump casing materials are GG 25, Bronze, GGG 40 and GS.

NM End Suction Centrifugal Pumps

Moment Of Inertia without Coupling

PUMP TYPE	MOMENT OF INERTIA I [kgm ²]					
	Impeller GG 25 ($\rho=7,3 \text{ kg/dm}^3$)		Impeller Bronze ($\rho=8,7 \text{ kg/dm}^3$)		Impeller Cast Steel ($\rho=7,8 \text{ kg/dm}^3$)	
	without	with	without	with	without	with
	water	water	water	water	water	water
NM 32-160	0,0062	0,0072	0,0074	0,0084	0,0066	0,0076
NM 32-200	0,0123	0,0142	0,0147	0,0166	0,0131	0,0150
NM 32-250	0,0212	0,0272	0,0309	0,0381	0,293	0,345
NM 40-160	0,0065	0,0072	0,0078	0,0085	0,0070	0,0077
NM 40-200	0,0124	0,0145	0,0148	0,0169	0,0132	0,0153
NM 40-250	0,0293	0,0355	0,0349	0,0411	0,0313	0,0375
NM 50-160	0,0075	0,0087	0,0219	0,0231	0,0080	0,0092
NM 50-200	0,0136	0,0160	0,0142	0,0186	0,0125	0,0169
NM 50-250	0,0318	0,0380	0,0379	0,0441	0,0340	0,0402
NM 50-315	0,0645	0,0800	0,0788	0,0943	0,0696	0,0941
NM 65-160	0,0077	0,0100	0,0092	0,0115	0,0082	0,0105
NM 65-200	0,0150	0,0192	0,0179	0,0221	0,0160	0,0202
NM 65-250	0,0375	0,0465	0,0447	0,0537	0,0401	0,0491
NM 65-315	0,0745	0,0900	0,0888	0,1043	0,0796	0,0951
NM 65-400	0,2100	0,2575	0,2522	0,2997	0,2251	0,2726
NM 80-160	0,0098	0,0127	0,0117	0,0146	0,0105	0,0134
NM 80-200	0,0195	0,0255	0,0232	0,0292	0,0208	0,0268
NM 80-250	0,0400	0,0525	0,0477	0,0602	0,0427	0,0552
NM 80-315	0,0845	0,1077	0,1007	0,1239	0,0903	0,1135
NM 80-400	0,2200	0,2675	0,2622	0,3097	0,2351	0,2826
NM 100-200	0,0253	0,0327	0,0302	0,0376	0,0270	0,0344
NM 100-250	0,0448	0,0625	0,0534	0,0711	0,0479	0,0656
NM 100-315	0,0895	0,1205	0,1067	0,1377	0,0956	0,1266
NM 100-400	0,2108	0,2650	0,2512	0,3054	0,2252	0,2794
NM 125-200	0,0375	0,0545	0,0447	0,0617	0,0401	0,0571
NM 125-250	0,0520	0,0740	0,0556	0,0776	0,0620	0,0840
NM 125-315	0,1058	0,1480	0,1261	0,1683	0,1130	0,1552
NM 125-400	0,2358	0,3098	0,2810	0,3550	0,2520	0,3260
NM 150-200	0,0475	0,0645	0,0547	0,0717	0,0501	0,0671
NM 150-250	0,0675	0,0975	0,0804	0,1104	0,0721	0,1021
NM 150-315	0,1507	0,2123	0,1796	0,2412	0,1610	0,2226
NM 150-400	0,2707	0,3608	0,3226	0,4127	0,2892	0,3793
NM 150-500	0,6760	0,8450	0,8056	0,9746	0,7223	0,8913
NM 200-280	0,1607	0,2223	0,1896	0,2512	0,1710	0,2326
NM 200-315	0,3007	0,3908	0,3526	0,4427	0,3192	0,4093
NM 200-400	0,4030	0,5440	0,4803	0,6213	0,4306	0,5716
NM 200-500	0,7728	0,9815	0,9210	1,1297	0,8257	1,0344

NM End Suction Centrifugal Pumps

Moment Of Inertia Without Coupling

PUMP TYPE	MOMENT OF INERTIA I [kgm ²]					
	Impeller GG 25 ($\rho=7,3 \text{ kg/dm}^3$)		Impeller Bronze ($\rho=8,7 \text{ kg/dm}^3$)		Impeller Cast Steel ($\rho=7,8 \text{ kg/dm}^3$)	
	without	with	without	with	without	with
	water	water	water	water	water	water
NM 250-315	0,2167	0,3077	0,2583	0,3493	0,2315	0,3225
NM 250-400	0,5595	0,7442	0,6668	0,8515	0,5978	0,7825
NM 250-500	0,9322	1,1932	1,1110	1,3720	0,9961	1,2571
NM 300-315	0,3595	0,4442	0,4668	0,5515	0,3978	0,5825
NM 300-400	0,4400	0,5985	0,5244	0,6829	0,4701	0,6286
NM 350-450	1,2000	1,850	1,4301	2,0801	1,2822	1,9322

For the water filling $\rho=1 \text{ kg/dm}^3$ is used. In case the handled liquid has a different density or the impeller is made of other materials having also a different density, calculate moment of inertia according to the following examples.

Example: Pump Size NM 100-250

Handled liquid density $\rho=1,25 \text{ kg/dm}^3$, impeller cast iron GG $\rho=7,3 \text{ kg/dm}^3$
 $I = (0,0625 - 0,0448) \times 1,25 + 0,0448 = 0,0669 \text{ kgm}^2$

Handled liquid density $\rho=1 \text{ kg/dm}^3$, impeller $\rho=8 \text{ kg/dm}^3$ (conversion from GG $\rho=7,3 \text{ kg/dm}^3$)
 $I = 0,0448 \times 8/7,3 + (0,0625 - 0,0448) = 0,0668 \text{ kgm}^2$

Handled liquid density $\rho=1.25 \text{ kg/dm}^3$, impeller $\rho=8 \text{ kg/dm}^3$
 (Conversion from GG $\rho=7,3 \text{ kg/dm}^3$ and water $\rho=1 \text{ kg/dm}^3$)
 $I = 0,0448 \times 8/7,3 + (0,0625 - 0,0448) \times 1,25 = 0,0712 \text{ kgm}^2$

NM End Suction Centrifugal Pumps

Exploded View

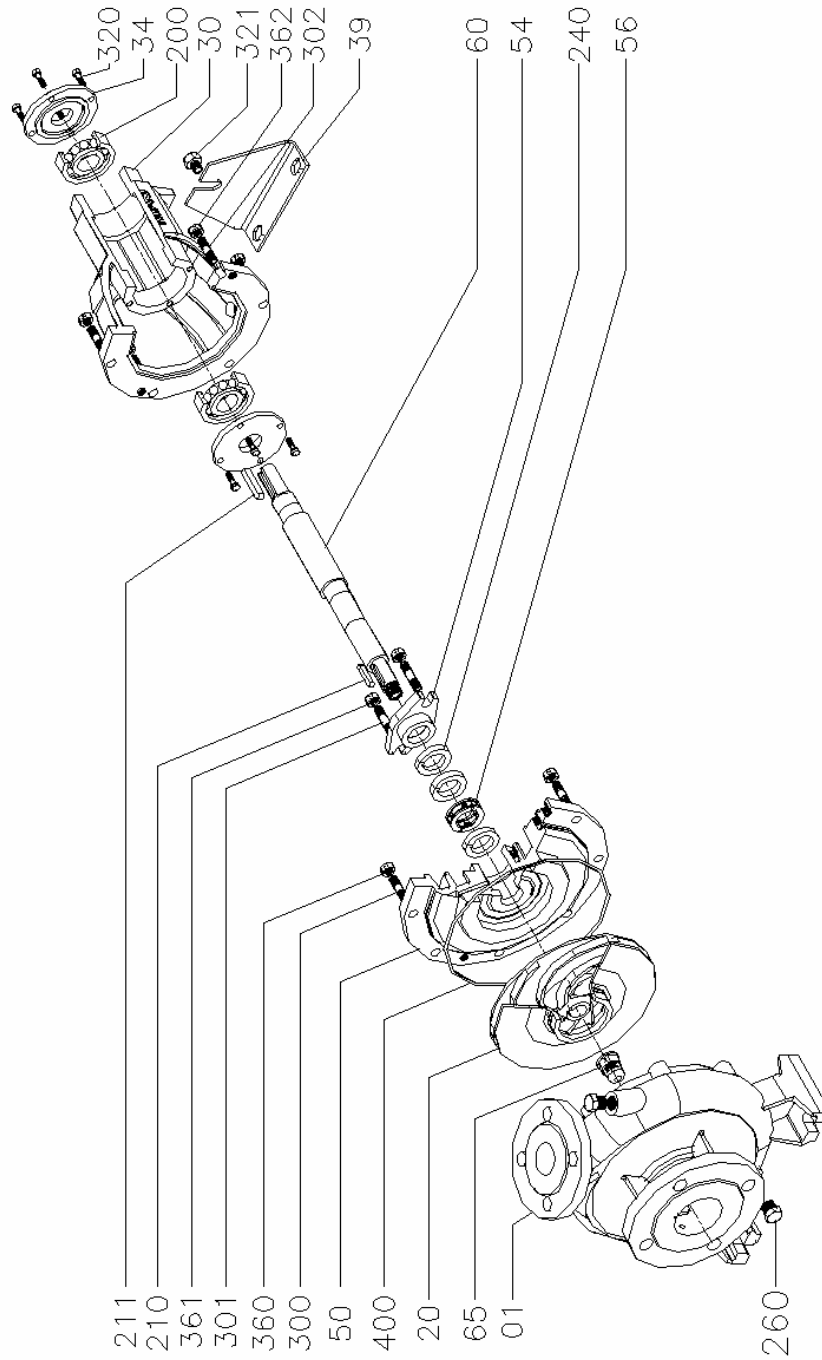

PART NO	PART NAME	PART NO	PART NAME
01	Pump Casing	211	Coupling Key
20	Impeller	240	Gland Packing
30	Bearing Housing	260	Drain Plug
34	Bearing Housing Cover	300	Stud
39	Supporting Foot	301	Stud for Gland
50	Stuffing Box	302	Stud
54	Gland	320	Hexagonal Bolt
56	Lantern Ring	321	Hexagonal Bolt
60	Pump Shaft	360	Hexagonal Nut
65	Impeller Nut	361	Hexagonal Nut for Gland
200	Ball Bearing	362	Hexagonal Nut
210	Impeller Key	400	O-Ring

